

MODEL OE2041

DSP Lock-In Amplifier



Copyright © 2020 by SSI.
All Rights Reserved.

Revision 1.0.0

1. SPECIFICATIONS	1
1.1 Signal Channel	1
1.2 Reference Channel.....	1
1.3 Demodulator	2
1.4 Internal Oscillator.....	2
1.5 Displays	2
1.6 Outputs	2
1.7 Interface.....	3
1.8 General.....	3
2. LOCK-IN AMPLIFIER BASICS	5
2.1 Introduction.....	5
2.2 Functional Diagram	7
2.3 Reference Channel.....	7
2.4 Phase Sensitive Detectors	8
2.5 Time Constants and DC Gain.....	10
2.6 DC Outputs and Scaling.....	12
2.7 Dynamic Reserve	14
2.8 Signal Input Amplifier and Filters.....	15
2.9 Input Connections.....	17
2.10 Intrinsic Noise Sources.....	18
2.11 External Noise Sources	20
2.12 Noise Measurement	23
2.13 Aux In/Out.....	23
2.14 Sweep Frequency and Amplitude of Signal Generator.....	24
2.15 Multi-harmonic Detection.....	24
3. INTERFACES	25
3.1 Front Panel	25
3.2 Rear Panel.....	26
3.3 Main Display	27
3.3.1 Status Bar.....	27
3.3.2 Data Bar	29
3.3.3 Monitoring Bar.....	29
3.3.4 Function Bar.....	30
4. MENU	31
4.1 [INPUT/FILTERS]	31
4.1.1 <Source>: Setting the Input Signal Mode.....	31
4.1.2 <Impedance>: Setting the Input Impedance.....	31
4.1.3 < Grounding >: Setting the Ground Mode.....	31
4.1.4 < Coupling >: Setting the Coupling Input Mode.....	32
4.2 [REF/PHASE]	32
4.2.1 < Ref. phase >: Setting the Reference Phase	34
4.2.2 < Ref. source>: Setting the Reference Source.....	34
4.2.3 < Ref. slope>: Setting the External Signal Mode.....	34

4.2.4 < Ref. frequency>: Setting the Internal Reference Frequency	35
4.2.5 < Sweep>: Setting the Internal Reference Signal Sweep	35
4.3 [GAIN/TC]	37
4.3.1 <Sensitivity>: Setting the Full Scale Sensitivity	37
4.3.2 <Gain>: Setting the Input Gain	37
4.3.3 < Time Constant >: Setting the Time Constants	39
4.3.4 < Filter dB/oct >: Setting the Roll off Slope of the Low Pass Filter.....	39
4.3.5 < Synchronous >: Setting the Status of the Synchronous Filter.....	40
4.4 [DEMODO]	40
4.4.1 < Demodulator >: Setting the Choice of Demodulator.....	41
4.4.2 < Demod.Type >: Setting the Mode of Demodulator	41
4.5 [DISPLAY].....	42
4.5.1 < Monitor >: Setting the Display of Status Bar.....	43
4.5.2 < Display Mode >: Setting the Display Mode of Dynamic Area	44
4.5.3 <Top Window>&<Bottom Window>: Setting the Column Window Display Content.....	44
4.6 [SINE/OUT].....	45
4.6.1 < Add Mode >: Setting the ADD IN Interface.....	45
4.6.2 < Output Mode >: Setting the Output Mode.....	46
4.7 [AUTO SET].....	48
4.7.1 < Auto Range >: Automatically Setting Measurement Range	48
4.7.2 < Auto Gain >: Automatically Setting Input Gain.....	48
4.7.3 < Auto Phase >: Automatically Setting Phase Adjustment	48
4.8 [CHOUT/AUXOUT].....	49
4.8.1< CH Output >: Setting the CH channel choice	50
4.8.2< Source >: Setting the Output Source of Channels	50
4.8.3< Offset&Expand >: Setting the Offset and Expand	51
4.8.4< Speed >: Setting the Output Speed.....	51
4.9 [SYSTEM].....	52
4.9.1 < Info > Secondary Submenu	52
4.9.2 < Screen > Secondary Submenu.....	53
4.9.3 < Remote > Secondary Submenu.....	54
4.9.4 < Reset >: The Lock-in Reset	58
4.10 [SAVE/RECALL]	58
5. REMOTE PROGRAMMING	59
5.1 OE2041 Command Syntax.....	59
5.2 Detailed Command List	59
5.2.1 Input and Filter Commands (Reference and Phase Commands)	60
5.2.2 Sensitivity and Time Constants Commands (Equation Commands).....	60
5.2.3 Reference and Phase Commands.....	62
5.2.4 Sine Wave Output Commands.....	64
5.2.5 Channel Output Commands	65
5.2.6 Auto Set Commands	66

5.2.7 Save and Recall Setup Commands	66
5.2.8 Reset and IDN Commands (Data Store Commands)	66
5.2.9 Data and Status Read Commands	67
5.2.10 Global Data & Configuration Read Command	69
6. COMPUTER OPERATION	72
6.1 Install Software	72
6.2 How to Use the Software	76
6.2.1 Begin to Run	76
6.2.2 Connection	77
6.2.3 Input Configuration	78
6.2.4 Reference and Frequency Sweep Configuration	79
6.2.5 Sensitivity and Gain Configuration	82
6.2.6 Auto Setting Configuration	83
6.2.7 Filter Configuration	83
6.2.8 Output Configuration	85
6.2.9 Sine Output Configuration	86
6.2.10 Demodulator Configuration	88
6.2.11 Save and Recall System Configurations	89
6.2.12 Data Storage	90
6.2.13 Waveform Display	91
6.3 Usage Examples	92
7. PERFORMANCE TESTS	97
7.1 Starting Test	99
7.2 DC Offset	99
7.3 Common Mode Rejection	99
7.4 Amplitude Accuracy and Flatness	100
7.5 Amplitude Linearity	101
7.6 Frequency Accuracy	102
7.7 Sine Output Amplitude Accuracy and Flatness	103
7.8 DC Outputs and Inputs	104
7.9 Input Noise	105
7.10 OE2041 Performance Test Record	106
8. OPERATION EXAMPLES	110
8.1 Simple Signal Measurements	110
8.2 Harmonics Measurements	113
8.3 Optical Spectral Measurement	116
8.4 Serial Communication	119

1. SPECIFICATIONS

1.1 Signal Channel

Voltage Inputs	Single-ended (A) or differential (A-B).
Full Scale Sensitivity	1 nV to 1 V in a 1-2-5 sequence.
Input Impedance	Configurable to 50 Ω //5 pF or 10 M Ω //5 pF, AC or DC coupling
CMRR	> 70 dB to 100 Hz, > 50 dB to 100 kHz
Dynamic Reserve	> 120 dB.
Gain Accuracy	0.5% typ (< 1 MHz), 3% max.
Voltage Noise	
@997Hz	10 nV/ $\sqrt{\text{Hz}}$ (Typ).
@99.99kHz	6 nV/ $\sqrt{\text{Hz}}$ (Typ).
Grounding	BNC (A, B) shields can be grounded or floated via 1 k Ω to ground.

1.2 Reference Channel

Input	
Frequency Range	1 mHz to 60 MHz.
Reference Input	TTL or Sine.
Impedance	1 M Ω .
TTL Reference Voltage	$V_{IH} > 3V$, $V_{IL} < 5V$.
Sine Reference Signal	Frequency > 1Hz, 200mV < V_{pp} < 10V.
Phase	
Resolution	0.01°.
Absolute Phase Error	< 1° typ (< 1 MHz), 5% max.
Relative Phase Error	< 0.01°.
Orthogonality	
Internal ref.	Synthesized, < 0.0001°rms at 1kHz.
External ref.	0.005°rms at 1kHz (125 ms time constant, 12 dB/oct).
Drift	
below 10 kHz	< 0.01°/°C.
above 10 kHz	< 0.1°/°C.
Harmonic Detection	2F, 3F, ...nF to 60 MHz (n<32,767).
Acquisition Time	
Internal Ref.	Instantaneous acquisition.
External Ref.	(2 cycles + 5 ms) or 40 ms.

1.3 Demodulator

Stability	
Digital Outputs	No zero drift on all settings.
Displays	No zero drift on all settings.
Analog Outputs	< 5 ppm/°C for all dynamic reserves.
Harmonic Rejection	-90 dB
Time Constants	30ns to 4.4ks, 6, 12, 18, 24, 30, 36, 42, 48 dB/oct roll-off.
Synchronous Filter	Available below 200 Hz and above 18 dB/oct.

1.4 Internal Oscillator

Frequency	
Range	1 mHz to 60 MHz
Accuracy	2 ppm + 10 μ Hz
Resolution	1 mHz
Distortion	-80 dBc (f < 10 kHz), -70 dBc (f > 10 kHz)
Sine Amplitude	1 μ Vrms to 1 Vrms with 1 μ Vrms resolution
Error	0.5% typ (f < 1 MHz), 1% max.
Temperature Stability	50 ppm/°C
Sine Outputs	Sine, output impedance is 50 Ω .
TTL Outputs	5 V TTL/CMOS voltage, output impedance is 50 Ω

1.5 Displays

Screen	5.6 inch, 640×480 TFT color LCD
Screen Format	Single or dual display.
Display Quantities	Each display shows one trace, traces can be defined as X, Y, R, θ .
Display Types	Large numeric readout, bar graph, polar plot and strip chart.
Color Style	Yellow, green

1.6 Outputs

AUX Inputs	
Function	Four channels for input.
Amplitude	\pm 10 V, 0.1 mV resolution, 0.1%+20mV accuracy.
Impedance	1 M Ω
AUX Outputs	
Function	Four channels for output.

Amplitude	± 10 V, 0.1 mV resolution, 0.1%+20mV accuracy.
Drive Current	± 60 MA max.
Clock Input	
Function	Input interface of external 10 MHz clock.
Voltage	3.3V TTL/CMOS.
Clock Output	
Function	Output interface of 10 MHz clock.
Voltage	3.3V TTL/CMOS.
Sync Input	
Function	Input interface of synchronous signal from other OE2041 lock-in amplifiers.
Voltage	3.3 V TTL/CMOS.
Sync Output	
Function	Output interface of synchronous signal to other OE2041 lock-in amplifiers.
Voltage	3.3 V TTL/CMOS.
Monitor Output	
Function	Analog output of signal amplifiers.
Drive Current	± 40 mA max.

1.7 Interface

RS-232	Standard 9-pin RS-232 female socket
USB2.0	USB2.0 high-speed interface
Ethernet	1000Mbps Gigabit network interface

1.8 General

Power Requirements	
Voltage	220~240 V AC
Frequency	50 Hz
Power	50 W typ, 70 W max.
Power Noise Rejection	70 dB @ 1 MHz
Weight	26.456 lb. (12 kg)
Dimensions	
Width	17.7 " (448mm)
Depth	
With handle	20.3 "(515mm)
Without handle	18.5 "(470mm)
Height	
With feet	5.9 "(148mm)
Without feet	5.3 "(133mm)

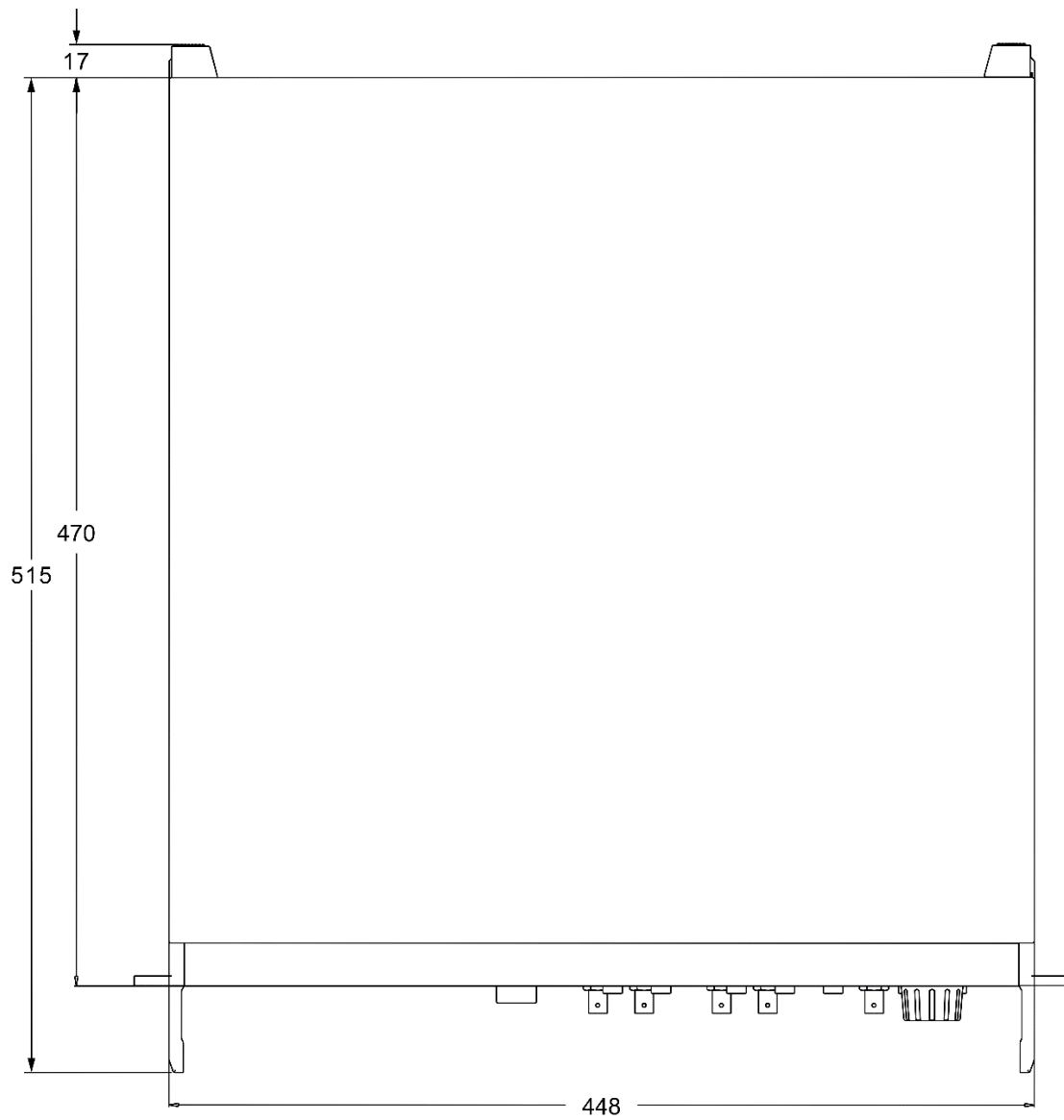
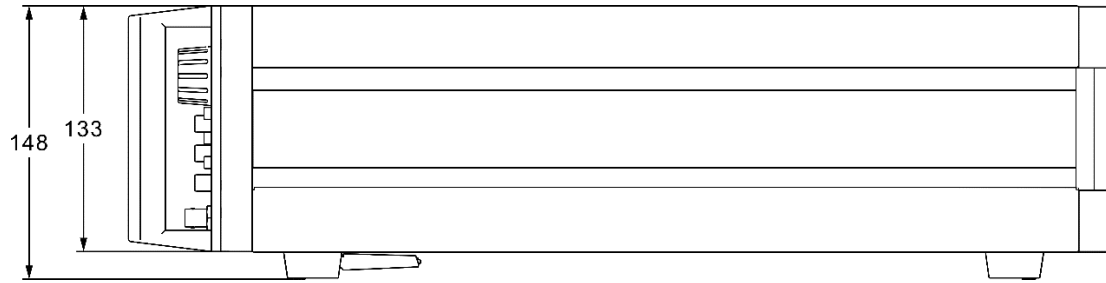

2. LOCK-IN AMPLIFIER BASICS

2.1 Introduction

The Lock-in amplifier is a device used to detect very small signals, which are always obscured by noise sources many thousands of times larger. The lock-in amplifier can extract these small signals from noises and measure their values accurately.

The lock-in amplifier is a weak signal detection method based on the coherence. Lock-in amplifiers use a key technique known as phase-sensitive detection (PSD) to single out the required component of the signal. This component has the same frequency with the reference signal and also has a fixed phase differences with the reference signal. Noise signals at other frequencies are rejected and do not affect the measurement.

The basic processing of small signals is amplification. Traditional amplifiers will amplify both the noise signals and the required signals. If there is no band limiting or filtering, amplification will decrease the signal to noise ratio (SNR). Therefore, filtering is needed to purify the signal and increase the SNR in order to measure the weak signal accurately.

PSD can be seen as a band-pass filter with a very narrow bandwidth. The basic modules of PSD include a multiplier module and a low-pass filter (LPF) module, as shown in Fig.1. Sometimes PSD is described as a multiplier module without a LPF.

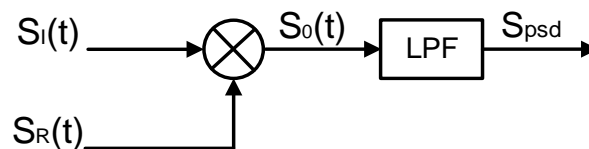

Fig.1 PSD diagram.

In Fig.1, $S_I(t)$ is the input signal plus noise in time region, $S_R(t)$ is the reference signal which has a fixed frequency with the test signal.

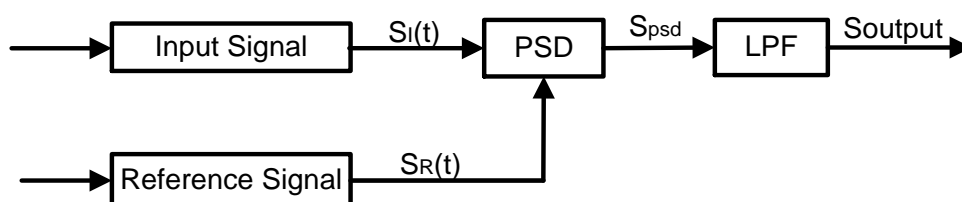

Fig.2 Single-phase amplifier diagram.

In Fig.2, the input signal $S_I(t)$ is defined as: $S_I(t) = A_I \sin(\omega t + \varphi) + B(t)$, where ω is the frequency of input signal, $A_I \sin(\omega t + \varphi)$ is the test signal, $B(t)$ is the total noise.

The reference signal $S_R(t)$ is defined as: $S_R(t) = A_R \sin(\omega t + \delta)$.

These two signals enter the PSD module for multiplication simultaneously, and the output of the PSD is defined as:

$$S_{psd} = S_I(t)S_R(t) = A_I A_R \sin(\omega t + \varphi) \sin(\omega t + \delta) + B(t)A_R \sin(\omega t + \delta)$$

$$= \frac{1}{2} A_I A_R \cos(\varphi - \delta) - \frac{1}{2} A_I A_R \cos(2\omega t + \varphi + \delta) + B(t)A_R \sin(\omega t +$$

$\delta)$

In time region, the output of the PSD is made up of three parts:

The first part is a DC signal. If A_I , A_R and the phase difference $(\varphi - \delta)$ between the input signal and the reference signal are constants, this part is a DC signal.

The second part is the frequency-doubled reference AC signal.

The third part is the result of multiplication between the noise signal and the reference signal. Because the sine signal is periodic and there is no relevance between the noise signal and the reference signal. The integral of this part is zero.

In frequency region, we can redraw these three parts:

The first part is at 0Hz, which is known as the DC component of one signal.

The second part is at $2f_{ref}$ Hz.

The third part is a random signal at all the frequencies, such as white noise. The frequency spectrum of white noise does not change after any frequency drifts.

To sum up, the LPF output is defined as: $S_{Output} = \frac{1}{2} A_I A_R \cos(\varphi - \delta)$.

Although we can determine the amplitude of the input signal through adjusting the phase difference $(\varphi - \delta)$, the accuracy is unsteady and insecure. In order to solve this problem, the dual phase lock-in amplifier was invented, see Fig.3.

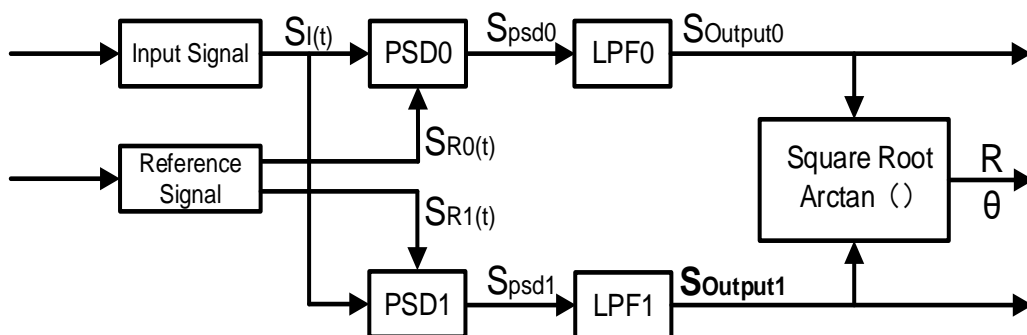

Fig.3 Dual Phase Lock-in Amplifier diagram.

Now, we define the phase difference $\theta = \varphi - \delta$, the LPF0 output $X = S_{Output0}$ and the LPF1 output $Y = S_{Output1}$. Then we calculate the amplitude R which is independent of θ :

$$R = \frac{A_I}{\sqrt{2}} = \frac{\sqrt{2(X^2 + Y^2)}}{A_R}$$

The phase difference is defined as: $\theta = \tan^{-1}(Y/X)$.

2.2 Functional Diagram

The functional block diagram of the OE2041 DSP Lock-In Amplifier is shown in Fig.4. On the whole, the OE2041 includes signal conditioners, reference signal generators, an algorithm module and a system control module and so on.

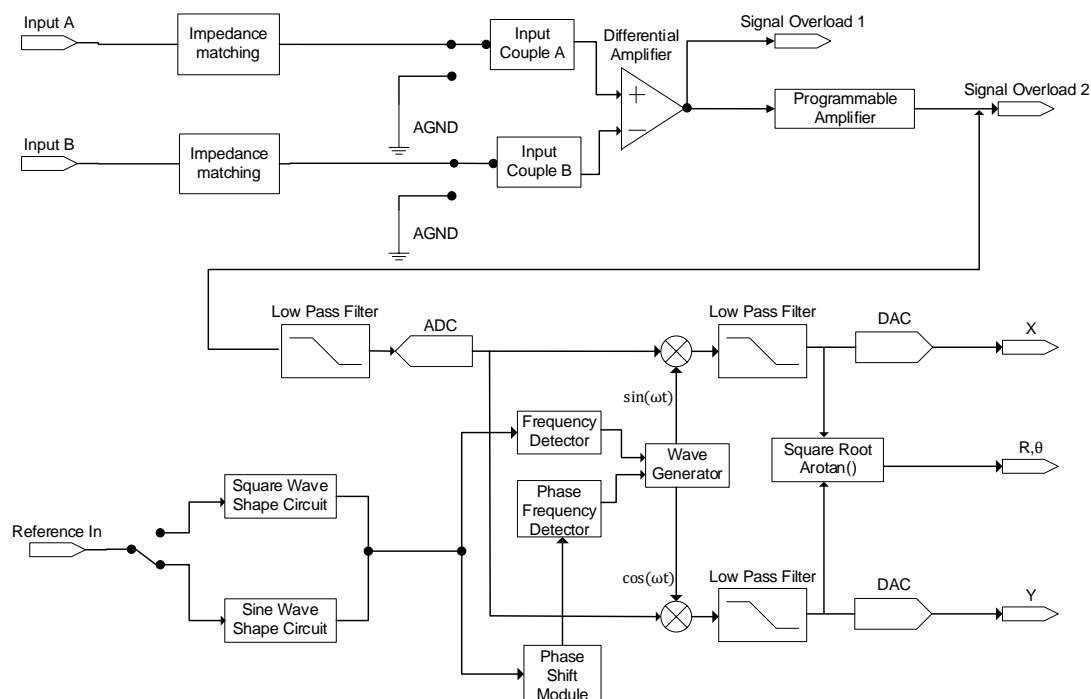

Fig.4 Functional Block Diagram of OE2041

2.3 Reference Channel

The function of the reference channel is to provide a control signal that is coherent with the detected signal for the phase-sensitive detector. The reference signal of the OE2041 can be selected as a sine wave or square wave signal according to the actual situation, and the input impedance of reference channel is 1 M Ω .

Normally both reference waveforms can be used. For TTL reference, a high level > 3V and a low level < 0.5V is required; sine reference is AC coupled and sine signal amplitude > 0.2Vpp is valid. However, when the frequency is below 1 Hz, the TTL level signal mode must be used. Since the signal-to-noise ratio of sine wave signal is low when the output amplitude is small, and the amplitude will be jittered, but many function generators can generate stable TTL synchronous signal, it is more recommended to use square wave signal as the reference signal.

The OE2041 lock-in amplifier has two reference signal modes: internal reference mode and external reference mode.

When set to the internal reference signal mode, the instrument's internal high-precision oscillator and synthesis algorithm can generate a sine wave signal for multiplying with the input signal, which does not need to be phase-locked with a phase-locked loop, and the internal reference signal is hardly affected by phase noise. The internal reference mode of the OE2041 can operate properly in the frequency range from 1 mHz to 60 MHz. Since the internal oscillator will have some frequency deviation from the oscillator of the external source and there is no phase lock loop tracking to lock it, there will be some frequency difference between the internally generated sine signal and the signal to be measured, and the phase stability between the two is not guaranteed.

The OE2041 is also capable of using an external reference signal mode, where sine wave signals and TTL logic levels can be used as external reference signals. The phase-locked loop generates a certain amount of phase jitter in practice, which may cause errors in the measurement. Phase jitter causes the reference signal to be mixed with noise of different frequencies. According to the PSD coherence principle, the output signal contains not only the signal to be measured with the same frequency as the reference signal, but also the noise of other frequencies in the reference signal. In fact, the phase jitter is generally small and does not cause measurement problems. If jitter-free measurements are required, the internal reference mode can be used. Since this mode does not use a phase-locked loop and the internal crystal is directly connected to the reference signal, there is no additional phase jitter interference.

2.4 Phase Sensitive Detectors

The phase sensitive detector (PSD) of the OE2041 is implemented by a digital multiplier. The input signal is amplified and filtered and then converted into a digital signal by a 24 bit A/D converter and input to the phase sensitive detector. Since the reference signal generated by the internal signal generator is also a digital quantity with a bit width of 24 bit, the accuracy of the phase sensitive detector module is 48 bit.

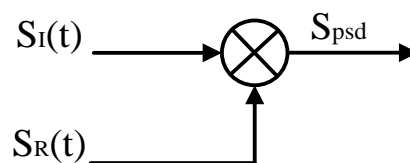

Fig.5 PSD diagram.

The phase-sensitive detector module of the lock-in amplifier mainly realizes the coherent modulation of the input signal and the reference signal, and the conventional lock-in amplifier realizes the above function by an analog multiplier. However, this method of coherent modulation by analog technology has many defects, it will not only greatly limit the accuracy of the phase sensitive detector but also introduce a lot of background noise, which is extremely unfavorable for the measurement of weak signals.

Based on the considerations above, this product uses digital technology to achieve coherent modulation of the signal. Since the reference signal generated by the internal signal generator is a digital signal with a bit width of 24 bits, it greatly avoids the effect of harmonic components on coherent modulation. In fact, the harmonic components can be suppressed up to -120 dB, which means that the harmonic components have almost no effect during the coherent modulation process.

In addition, because there is temperature drift and DC bias in the phase sensitive detector implemented by analog technology, so its output results often have a certain deviation from the actual results (i.e., systematic error, and this systematic error is often with uncertainty), while the phase sensitive detector implemented by digital technology can avoid this problem. In the case of normal system operation, the corresponding systematic error is almost never generated. Considering that the inputs of the analog multiplier are all analog, its reference signal is also affected by the temperature drift effect. This causes deviations to the reference signal as well, which in turn makes the coherent modulation results have a larger systematic error.

The dynamic reserve of phase-sensitive detectors implemented in analog technology is basically limited to less than 60 dB, because there is often a lot of background noise in analog systems. Since the lock-in amplifier is mainly used for detection of weak signals, the result of coherent modulation will be wrong when the amplitude of the background noise is close to or larger than the signal. The phase sensitive detector implemented by digital technology does not have such problems, and its dynamic reserve is mainly limited by the quality of the A/D conversion. Once the input signal is digitized, no additional errors are introduced in the process of coherent modulation. In fact, the dynamic reserve of the OE2041 can reach over 120 dB.

In summary, it can be seen that the phase sensitive detector realized by digital technology is better than the phase sensitive detector realized by analog technology in all aspects of performance, and the phase sensitive detector implemented by digital technology also has the advantages of easy debugging, thus becoming the best choice for this product.

2.5 Time Constants and DC Gain

The output signal of the PSD contains many signals of various frequency, such as the sum or difference between the input signal frequency and the reference frequency. Only the signal whose frequency is exactly equal to the reference frequency will result in a DC output.

The output of the phase-sensitive detector contains a variety of frequency components of the signal, the sum or difference between the input signal frequency and the reference frequency. Only the signal whose frequency is exactly equal to the reference frequency will result in a DC output. The low-pass filter following the phase-sensitive detector can filter out the noise signal and the sum frequency signal except for the DC component, so that the lock-in amplifier has the function of a high-quality band-pass filter.

Time Constants

The bandwidth setting of the low pass filter is the same as the conventional low pass filter. They are both determined by the time constants. The calculation of the time constant is defined as:

$$TC = \frac{1}{2\pi f}$$

Here f is the -3dB frequency of the low-pass filter. For example, to a one-order low pass filter of RC type, a 1s time constant means its -3dB point occurs at 0.16Hz.

In fact, where there is an input noise, there is an output noise. By increasing the time constant, the output becomes more stable and measurement becomes more reliable. The time constant reflects not only the stability of the system and the accuracy, but also the respond time of the output. For the first-order RC low-pass filter, it is necessary to wait for more than 5 times the time constant to make the output stable.

The time constant also determines the equivalent noise bandwidth (ENBW) for noise measurements. As a special note, the equivalent noise bandwidth does not refer to the -3 dB bandwidth of the filter, it refers to the effective bandwidth for Gaussian noise.

Equivalent noise bandwidth and response wait time of each order of RC low-pass filter are shown in Table 1.

Table 1 ENBW and response wait time of each order of RC low-pass filter

Filter order	Steep drop	Equivalent noise bandwidth	Time required for output to reach 99% stability
1	6 dB/oct	$0.25 \div TC$	$4.6 \times TC$
2	12 dB/oct	$0.125 \div TC$	$6.6 \times TC$

3	18 dB/oct	$0.09375 \div TC$	$8.4 \times TC$
4	24 dB/oct	$0.07813 \div TC$	$10 \times TC$
5	30 dB/oct	$0.06836 \div TC$	$11.6 \times TC$
6	36 dB/oct	$0.06152 \div TC$	$13.1 \times TC$
7	42 dB/oct	$0.0564 \div TC$	$14.6 \times TC$
8	48 dB/oct	$0.05237 \div TC$	$16 \times TC$

Digital Filters vs Analog Filters

To maximize the performance of the OE2041, we use a digital filter to implement low-pass filtering of the coherent modulation results. As with most analog versus digital systems, the digital system has many advantages that the analog system does not have. First, the temperature drift and nonlinearity inherent in analog devices will greatly limit the degree of filter roll-off. Second, to build a low-pass filter with large time constants and high quality through analog devices requires a considerable board area, which will not only make the cost of the instrument rise, but also the large number of analog devices will make future debugging very difficult.

The low-pass filter implemented digitally in this product is a narrow-band filter with 48-bit width, DC gain of 0 dB, and equivalent Q value of up to 145 dB or more.

Synchronous Filters

Another advantage of digital filtering is to do synchronous filtering. Even if the input signal has no noise, the PSD output always contains a component at 2F (sum frequency of the signal and the reference) whose amplitude may exceed the difference frequency component that we want. At lower frequencies, the time constant required to filter out the 2F frequency can be large. For example, if the input signal is a 1 Hz frequency waveform, then the 2F frequency is 2 Hz. Even with a second-order RC filter with a 10 second time constant, the attenuation for the 2 Hz frequency position is only 40 dB or so.

The synchronous filter is an averaging algorithm that averages all data within one full cycle time of the reference frequency, allowing effective filtering of all octave components of the reference frequency. In the above example, if the synchronous filter is used, only 1 second of waiting time is needed to achieve better results than the RC filter with a 10 second time constant.

In OE2041, synchronous filters are available at detection frequencies below 200 Hz. At higher frequencies, the filters are not required because the 2F component is easily removed without using long time constants. The output of the synchronous filter is followed by two more stages of normal filters. This combination of filters can eliminate the harmonics of the reference signal and attenuate other noise signals.

Long Time Constants

Time constants above 100s are difficult to accomplish by using analog filters. This is simply because the capacitors required for the RC filters are prohibitively large in value and size. Why would you use such a long time constant? Sometimes you have no choice. If the reference is below 1 Hz with a lot of noise at low frequency, the PSD output will contain many low frequency components. But the synchronous filter only filters out the harmonic component of the reference frequency, and the noise is filtered by the followed filters.

The OE2041 provides time constants as long as 4400s, which can satisfy most requirements of measurements.

DC Output Gain

How big is the DC output from the PSD? It depends on the dynamic reserve. With a 60 dB dynamic reserve, a noise signal can be 1000 times (60 dB) greater than full scale signal. At the PSD, the noise cannot exceed the input range of PSD. For example, in an analog lock-in, the PSD input range might be 5 V. With 60 dB dynamic reserves, the signal will be only 5 mV at the PSD input. The PSD typically has no gain so the DC output from the PSD will only be a few millivolts. Even if the PSD had no DC output errors, amplifying this millivolt signal up to 10 V is error prone. An offset as small as 1 mV will appear as 1 V at the output. This is one of the reasons why analog lock-in does not perform well at high dynamic reserve.

The digital lock-in does not have an analog DC amplifier, and has no DC output offset. Likewise, the digital DC amplifier has no input offset. The output of digital DC amplifier is simply the products of multiplying the input signal by the gain. This allows the OE2041 to operate with 120 dB of dynamic reserve without any output offset or zero drift.

2.6 DC Outputs and Scaling

The OE2041 has 4 output channels from CH1 to CH4 on the rear panel.

CH1 and CH2 Outputs and Display

The output range of CH1 and CH2 is from -10V to 10V.

The output signal is proportional to the value of the test signal and the setting scale. Otherwise, the OE2041 shows the value of CH1 to CH4 on the front panel, including the value of X, Y, R, θ of the test signal. The display interface of OE2041 is shown in Fig.6. This product can display data in the form of a bar graph in addition to the usual numerical display.

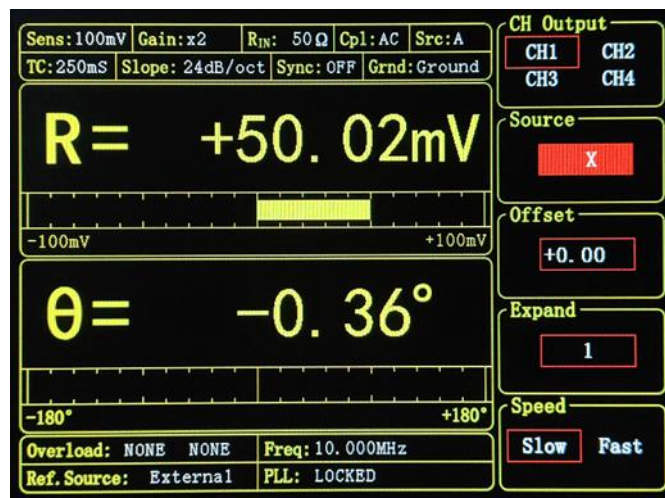

Fig.6 Output Setting Interface of OE2041

X, Y and R Output Offset and Expand

The OE2041 has the ability to offset the X, Y and R outputs, which is useful when measuring deviations in the signal around some nominal value. Because the offset can be set anywhere in the range, the offset of the output can be said to be almost zero. The change in output can be read directly from the output of the display or panel. The offset is expressed as a percentage of the full scale output, and this ratio does not change as a result of changes in sensitivity. The offset can be set to a maximum of $\pm 100\%$ of the full scale output.

The X, Y and R outputs can be expanded. It's realized by multiplying the output with an expansion factor. Thus, a signal which is only 10% of full scale can be expanded to provide 10 V rather than 1 V. The general use for expansion is to increase the measurement resolution around some value which is not zero.

When the output does not exceed full scale, the OE2041 can expand the output by multiplying the expansion factor from +1 to +256. The output with offset and expand is:

$$\text{Output} = \left(\frac{\text{Signal}}{\text{Sens}} + \text{Offset} \right) \times \text{Expand} \times 10(\text{V})$$

where <Offset> can be set $\pm 100\%$ by the digital keyboard and the minus step is 0.01%. <Expand> can be set from +1 to +256 by the digital keyboard and the minus step is 1. Related display interface is shown in Fig.7.

For example, there is:

$$\text{Output} = \left(\frac{0.1\text{mV}}{1\text{mV}} + 0.2 \right) \times 2 \times 10(\text{V}) = 6(\text{V})$$

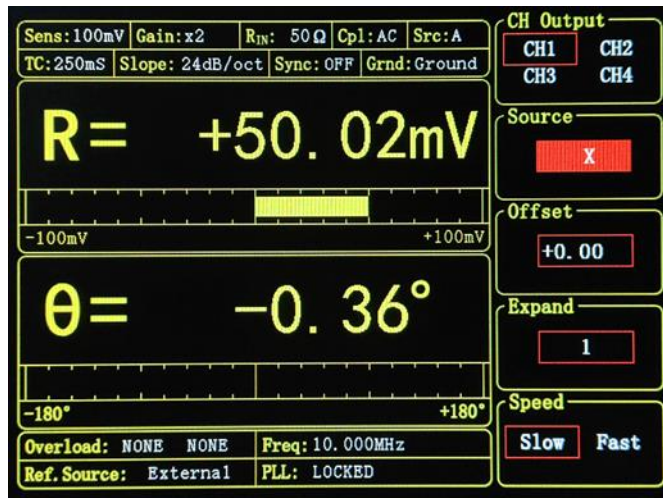

Fig.7 Output Offset and Expand

2.7 Dynamic Reserve

The definition of dynamic reserve is the ratio of the largest tolerable noise signal to the full scale signal, expressed in dB, which is defined as:

$$\text{Dynamic reserve} = 20(\text{OVL}/\text{FS})(\text{dB})$$

Where OVL is the total dynamic range of the input signal. FS is the dynamic range of the output signal. If the dynamic reserve is 100 dB, the tolerable noise can be 10^5 times the input.

The 'tolerable' means that the noise at the dynamic reserve limit should not cause an overload anywhere in the instrument. Overload might appear at the input of the pre-amplifier and the output of DC amplifier. The input gain of the system is inversely proportional to the dynamic reserve, because noise is also amplified with the input gain, so high dynamic reserve can be achieved by reducing the input gain. The pre-amplifier gain is set to a more reasonable range to prevent noise overload. After the PSD and low-pass filter have filtered out most of the noise, the DC gain is set to a larger value to amplify the signal to full scale.

The input signal of the lock-in amplifier requires AC gain prior to PSD processing, while DC gain is sufficient after PSD processing. Suppose the total gain is a constant. If the AC gain increases and the DC gain decreases, the input noise is easy to overload after AC gain. Thus, the dynamic reserve and the DC drifts decrease. In contrast, if the AC gain decreases and the DC gain increases, the dynamic reserve increases. In this case, the output stability will decrease and the accuracy of measurement will be lower.

The noise frequencies and amplitudes affect the accuracy of the DC output signal. Noise at the reference frequency with large amplitude becomes part of the DC

signal after the PSD. This enlarges the output error of the lock-in amplifier.

The dynamic reserve is related to noise frequency. The dynamic reserve is 0dB at reference frequency and increases when the noise frequency moves away from the reference frequency. It reaches a maximum value when the frequency is far enough. The dynamic reserve near the reference frequency is important to noise tolerance of the instrument. Providing more low pass filter stages can improve the performance of the filters and then increase the dynamic reserve close to the reference frequency. The dynamic reserve far from the reference frequency is generally high but has little influence.

The dynamic reserve of OE2041 is greater than 120dB. High dynamic reserve will increase output noise and drift. When the dynamic reserve is high, output noise will be increased due to the A/D converter. There is background noise at any signal. When the signal is amplified by PSD, the output signal will contain noises. If the noise is very high, it will result in large output noise. Otherwise, if the external noise is very low, the output is mainly affected by the noise of OE2041. Reducing dynamic reserve and DC gain can decrease the error. Therefore, low dynamic reserve should be chosen firstly in actual application.

2.8 Signal Input Amplifier and Filters

A lock-in amplifier can measure signals as small as a few nanovolts. The gain of the low noise signal amplifier should be large enough so that the output signal can be digitized by the A/D converter without degrading the signal to noise (SNR). The analog gain in the OE2041 ranges from roughly 0.4 to 1500 times. Higher gains do not improve the SNR.

The overall gain (AC plus DC) is determined by the sensitivity and the distribution of the gain is set by the dynamic reserve.

Input Noise

In OE2041, the input noise is about $10\text{nV}_{\text{rms}}/\sqrt{\text{Hz}}$. If an amplifier has $10\text{ nV}_{\text{rms}}/\sqrt{\text{Hz}}$ of input noise and a gain of 1000, the output will have $10\text{ }\mu\text{V}_{\text{rms}}/\sqrt{\text{Hz}}$ of noise. Suppose the output of the amplifier is low-pass filtered by a single RC filter (6 dB/oct rolloff) with 100 ms time constant. Input noise of lock-in amplifier and Johnson noise of resistors are both Gaussian in nature. That is to say, the amplitude of noise is proportional to the square root of the noise bandwidth. A single-stage RC filter has an ENBW of $1/4T$ where T is the time constant ($R \times C$) which means that Gaussian noise is filtered with an effective bandwidth equal to ENBW. In this case, the filter sees $10\text{ }\mu\text{V}_{\text{rms}}/\sqrt{\text{Hz}}$ of input noise and has an ENBW of $1/(4 \times 100\text{ ms})$ or 2.5 Hz. The voltage noise at the filter output will be $10\text{ }\mu\text{V}_{\text{rms}}/\sqrt{\text{Hz}} \times \sqrt{2.5\text{Hz}}$ or

15.8 μV_{rms} . For Gaussian noise, the peak-peak noise is about 6.6 times the rms noise. Thus, the output noise will be about $104\mu\text{V}_{\text{pp}}$.

Input noise works the same way. At a set gain of 1500 times, the input gain reaches its maximum and the amount of input noise will determine the output noise. The equivalent noise bandwidth of the low-pass filter, in turn, affects the amount of noise at the output.

ENBW depends on the time constant and filter roll off (refer to chapter 2.5). For example, suppose the OE2041 is set to $<5\mu\text{V}>$ full scale, $<100\text{ms}>$ time constant and $<6\text{dB/oct}>$ roll off. Thus, ENBW is 2.5 Hz. This brings 7.9 nVrms input noise. At this setting, the noise equivalent to the input is 15.8 nVrms, the output is 0.32% of the range (i.e. $15.8\text{nV}/5\mu\text{V}$), and the peak-to-peak noise is about 2% of the full scale.

Assume that the signal input is from a low impedance source. The Johnson noise of resistors equals to $0.13\sqrt{R}$. Take a 100Ω resistor for example, its noise is almost $1.3\text{nV}_{\text{rms}}/\sqrt{\text{Hz}}$. When the impedance of the resistor is 10 k Ω , the Johnson noise is greater than the input noise of OE2041. The overall noise of multiple noise sources is determined by the square root of the sum of the squares of the individual noise figures. For example, if a 10k Ω source impedance is used, its own Johnson noise and the input noise of OE2041 are superimposed and the total noise is $\sqrt{10^2 + 13^2} = 16.4\text{ nV}_{\text{rms}}/\sqrt{\text{Hz}}$.

At low gains, the gain is not high enough to amplify the input noise to a level greater than the noise of the A/D converter. In these cases, the output noise is mainly the A/D noise. At these sensitivities, the DC gain is low and the noise at the output is negligible.

Anti-aliasing filter

After the trapper and amplifier circuit, the input signal passes through an anti-alias filter, which must be done before the signal can be digitized. According to Nyquist's theorem, the sampling frequency is at least twice the frequency of the signal. For example, if the signal frequency is 100kHz, then at least 200kHz sampling frequency is required for sampling. 250MHz is the sampling frequency of the A/D converter of the OE2041, and the A/D converter cannot convert signals higher than 125MHz, which would violate Nyquist's theorem and result in undersampling. The result of undersampling is that the high-frequency signal will appear in the low-frequency part of the digital stream output by the A/D converter, i.e., the signal will be mixed, causing measurement errors.

To avoid this situation of undersampling, the analog signal is first low-pass filtered to eliminate the high-frequency portion of the signal above 125 MHz. The low-pass

filter has a flat passband (0-60MHz), and signals in this frequency range are not affected. The high frequency portion of the signal above 60 MHz is gradually attenuated, and the transition phase from 60 MHz to 125 MHz produces a 100 dB attenuation of the signal and noise above the 125 MHz frequency.

Input Impedance

The OE2041 is available with either 50 Ω or 10 M Ω input impedance. If a higher input impedance is required, the OE2041's pre-amplifier, the OE400X series, can be used. The OE400X series pre-amplifiers are available with input impedances of 100 M Ω or higher to meet a variety of user scenarios.

2.9 Input Connections

Noise is present in all circuits. Even in the case of large signal amplitudes, noise can reduce the accuracy of the measurement. In order to obtain the best measurement accuracy, care must be taken to reduce avoidable sources of noise in the experimental environment. In addition to the inherent noise of the system, the influence of other noise sources (such as power supply noise, noise from the signal generator, electromagnetic fields distributed in space, etc.) and the ground level difference between different instruments and ground loop problems can be reduced at the link of the input connection.

There are two basic methods for input connection - the single-ended connection is more convenient while the differential connection eliminates spurious pick-up more effectively.

Single-Ended Connection (A)

In the first method, the lock-in uses the A/I input in a single-ended mode. The lock-in detects the signal as the voltage between the center and outer conductors of the A/I input only.

It is generally accepted that the ground level is a constant of 0 V. However, the ground levels of different instruments can vary slightly. When the ground level of the signal source is directly connected to the ground level of the test instrument, the difference in their levels will result in a large current, i.e., a ground loop, when the current of the instrument at the higher ground level all flows back to earth through the instrument at the lower ground level, which will lead to two serious problems: first, the noise of the instrument at the higher ground level is directly input into the instrument at the lower ground level, and second, the lower because of excessive current and damage. To solve this problem, the ground loop problem can be eliminated by connecting a resistor between two different levels of ground. In the OE2041, two resistance modes are available: Float and Ground, with a 1 k Ω

resistor for Float and a 0 Ω resistor short for Ground.

In addition, the single-ended connection mode is sensitive to noise. The single signal line is like an antenna and will be affected by the electromagnetic noise from the environment, and the shield will absorb this noise. Because the single-ended connection mode detects the voltage difference between the center signal line and the shield, so this noise will be carried inside the lock-in amplifier.

Differential Connection (A-B)

The differential connection mode has two signal lines connected to the signal source, each to the corresponding input (A/I, B). This mode detects the voltage difference between the center conductors of the A and B interfaces, and the noise absorbed by the shields of both interfaces is not acquired by the lock-in amplifier.

In this mode, take care that the two cables travel the same path between the experiment and the lock-in. There should not be a large loop area enclosed by the two cables. Otherwise, measurement is susceptible to magnetic pickup.

AC coupling and DC coupling modes

The OE2041 has two modes of AC coupling and DC coupling for the input signal. AC coupling filters out DC and lower frequency signals through a first-order RC high-pass filter (-3dB frequency is 0.16Hz). AC coupling should be used when the signal frequency is greater than 10Hz (to ensure passband flatness). For signals below 10Hz frequency, DC coupling mode should be used. DC coupling mode does not have any obstruction to the input signal.

If the input signal contains a DC component, which is not removed, then it poses several pitfalls: the DC component is also amplified in the amplifier circuit, and if it is amplified beyond the input range of the A/D converter, then it will cause errors in the measurement results and may also damage the A/D converter. In addition, the DC component is quantized into a digital quantity by the A/D converter and then multiplied with the reference sine signal in the PSD, then a more powerful low-pass filter is required to filter it out, which will result in a longer measurement time required.

When the frequency of the signal to be measured is greater than 10Hz, it is recommended to use AC coupling mode.

2.10 Intrinsic Noise Sources

Noise is defined as any negative factors which will affect the result of measurement.

Noise is random, unpredictable and temporary. Good experimental design should reduce the noise and improve the stability and accuracy of measurement. Some of noise is unavoidable which only can be decreased by signal averaging and a narrower bandwidth. Others can be decreased by filtering and perfect line structures and component layout. Meanwhile, amplifier itself also produces noise at work, which can be solved by low noise amplifier design techniques.

There are various intrinsic noise sources in electronic systems, and these noises have their physical meanings.

Johnson Noise

Every resistor generates a noise voltage across its terminals due to thermal fluctuations in the electron density within the resistor itself. This is Johnson noise. The spectrum of the Johnson noise is flat, so the noise power is almost the same in different frequency band (Of course there is an upper limit frequency). In this case, the noise is called white noise. The fluctuations give rise to an open-circuit noise voltage,

$$V = (4KTRB)^{1/2}$$

Where k is the Boltzmann's constant of $1.38 \times 10^{-23} \text{ J/}^\circ\text{K}$. T is the temperature in $^\circ\text{Kelvin}$, which can be transformed to $^\circ\text{Celsius}$: $^\circ\text{K} = ^\circ\text{C} + 273.16$. R is the resistance in Ohms, and B is the bandwidth of the measurement in Hz.

Nyquist described the features of Johnson noise in math, and found the power spectrum function of Johnson noise is:

$$S_t(f) = 4KTR(V^2/\text{Hz})$$

At 300°K , a resistor of $10 \text{ K}\Omega$ is connected to the input of the amplifier. The voltmeter is connected to the output of the amplifier. The open-circuit effective voltage of the filter which has a 10 kHz bandwidth is $1.3 \mu\text{V}$.

The amplitude of Johnson noise is unpredictable in normal case. But it follows the Gaussian distribution. Johnson noise is the minimum value of the noise voltage of any devices including detectors, signal sources and amplifiers with resistors. Johnson noise is a typical case of wave dissipation.

Shot Noise

Because of the finite nature of the charge carriers, electric current has noise. Noise generates in the current since there is always some non-uniformity in the electron flow. This noise is called shot noise. It appears as voltage noise when current is passed through a resistor, or as noise in a current measurement.

If ignore the effect between carriers, the shot noise or current noise is given by:

$$I = (2qI_{dc}B)^{1/2}$$

where q is the electron charge of 1.6×10^{-19} Coulomb, I_{dc} is the DC current and B is the bandwidth. If I_{dc} is 1 A DC current and B is 10 kHz, then, I is 57 nA which is about 0.000006% of I_{dc} . At a smaller current, the fluctuation is larger. For example, if I_{dc} is 1 μ A and B is still 10 kHz, then, I is about 0.006% or -85 dB. If I_{dc} is 1 pA, then, I is about 5.6% or 56 fA.

In fact, shot noise is one kind of the white noise. Its power spectrum density is given by:

$$S_{si}(f) = 2qI_{dc} \text{ (A}^2/\text{Hz)}$$

The formula is based on the assumption that carriers in the current do not affect each other. This assumption exists, such as the diffusion current in the junction diode. However, for general metal, this formula cannot be used because the cross effect between carries cannot be ignored.

Flicker Noise (1/f Noise)

In 1925, Johnson first found 1/f noise in in tube currents. The power spectrum function of this noise is proportional to 1/f. The lower the frequency, the more serious the noise. Thus, it is also called low frequency noise. Microscopically, 1/f noise is caused by the random value of contact resistance between two conductors. The current amplitude of 1/f noise follows the Gaussian distribution, and the power spectrum density is proportional to 1/f which is given by:

$$S(f) = \frac{KI_d^2}{f} \text{ (V}^2/\text{Hz)}$$

1/f noise is also called flicker noise due to the random fluctuation of the power spectrum density in active devices. It broadens the bandwidth near the center frequency and reduces the value of Q of oscillators. 1/f noise must be considered near the center frequency.

Johnson noise and shot noise are unreducible. Any resistors with a same resistance have the same Johnson noise. Shot noise relies on the special manufacture of resistors, including its material and package technology and so on. For example, among winding resistor, metal film, carbon resistor and pure carbon, the winding resistor has the minimum resistance. The metal film resistor and carbon resistor have larger resistances. The pure carbon resistor has the maximum resistance of these four. All of these noises are incoherent. The total random noise is the square root of the sum of the squares of all the incoherent noise sources.

2.11 External Noise Sources

In addition to the intrinsic noise sources discussed previously, there are different kinds of external noise sources. Most of these noise sources are asynchronous and not related to the reference. They do not occur at the reference frequency or its

harmonics. These noise sources affect the measurement mainly by increasing the requirement of dynamic reserve or lengthening the time constant. However, some external noise sources are related to the reference. If they are picked up in the signal, noise will add or subtract from the actual signal and cause errors in the measurement. Fortunately, external noise sources can be reduced through various ways.

Capacitive Coupling

The mutual capacity between wires is often called stray capacity C_{stray} . An AC voltage from a nearby piece of apparatus can couple to a detector via C_{stray} . Although C_{stray} may be very small, the coupled noise may still be larger than a weak experimental signal and cause severe instability for the detector. The noise current is given by:

$$I = \omega C_{\text{stray}} V_{\text{noise}}$$

where ω is 2π times the noise frequency, V_{noise} is the amplitude of noise, and C_{stray} is the stray capacitance.

When the noise sources' frequency become larger, the coupling noise will be larger. If the noise source is at the reference frequency, the noise will be quite large. The lock-in rejects noise at other frequencies, but pick-up at the reference frequency appears as signal.

Cures for capacitive noise coupling include:

- 1) Remove or turn off the noise source.
- 2) Design the experiment to measure voltages with low impedance for most of low frequency noise sources.
- 3) Install capacitive shielding by placing the experiment and detector in one metal box.

Inductive Coupling

An AC current in a nearby piece of apparatus can couple to the experiment via a magnetic field. A changing AC current gives rise to a changing magnetic field which induces voltage. The larger the frequency, the larger the electromotive force, the greater the measurement error.

Cures for inductively coupled noise include:

- 1) Remove or turn off the interfering noise source.
- 2) Reduce the area of the pick-up loop by using twisted pairs or coaxial cables.
- 3) Use magnetic shielding to prevent magnetic field from crossing the area of measurement.

Resistive Coupling or Ground Loops

The ground loop is an interference source which can generate noise voltage between the grounds. If the noise voltage is large enough, it will cause measurement errors. Ground loop is a physic loop, which generates from many ground methods. These grounding methods can act as a big loop wire. They pick up noises from the environment and generate voltages in the grounding system. The 50 Hz magnetic field of the AC power is a normal noise source that the ground loop always pickup. For distributed grounding systems, the ground voltage can cause the ground current flow in the ground loop. Since the ground is with low impedance, noise current is always very high.

Cures for ground loop problems include:

- 1) Connect all grounds to the same physical point.
- 2) Use a heavy ground bus to reduce the resistance of ground connections.
- 3) Remove sources of large ground currents from the ground bus.

Microphonics

Not all noise sources are electrical in origin. According to microphonic effects, mechanical noise can be transformed into electrical noise. Physical changes in the device or cables (such as vibrations) will cause electrical noise over the whole bandwidth of the lock-in.

Solutions to minimize microphonic signals:

- 1) Eliminate mechanical vibrations near the experiment.
- 2) Tie down cables carrying sensitive signals.
- 3) Use a low noise cable that is designed to reduce microphonic effects.

Thermocouple effects

When two dissimilar metals contact, there will be potential difference between them. The reason for potential difference includes: (1) different electronic work function of two metals. (2) different electron concentration of two metals.

Suppose that metal A and metal B have work functions V_a and V_b respectively. The electromotive force (emf) between A and B is:

$$V_{ab} = V_a - V_b + \frac{kT}{q} \times \ln\left(\frac{N_a}{N_b}\right)$$

Where K is Boltzmann's constant of $1.38 \times 10^{-23} \text{J/K}$, T is the temperature of °Kelvin, q is the electron charge of $1.60 \times 10^{-19} \text{Coulomb}$. It's found that from the formula, the contact potential depends on the nature of the metal and the temperature of the contact surface.

If two dissimilar metals contact, the electromotive force at the contact point will plus a slowly changing millivolt level. This kind of noise is sensitive to temperature. This

noise is typically at very low frequency because the temperature of the detector and experiment generally changes slowly. This effect is large on the scale of many detector outputs and can be a problem for low frequency measurements, especially in the mHz range.

Solutions to minimize thermocouple effects:

- 1) Hold the temperature of the detector or experiment constant.
- 2) Use a compensation junction.

2.12 Noise Measurement

OE2041 provides a noise measurement function that measures the noise of the input signal at the reference frequency. Some noise sources are frequency dependent and the lock-in amplifier can measure these noise sources.

Depending on the bandwidth of the RC filter set by the user, the lock-in amplifier can be understood as a bandpass filter with the reference frequency as the center frequency and a passband bandwidth twice the bandwidth of the RC filter. Therefore noise near the reference frequency is retained at the output. When the input signal is a noise source, then the lock-in amplifier can measure its noise value at the set frequency. If the frequency is measured in a swept manner, the noise power spectrum of the noise source can also be obtained.

The OE2041 measures noise by first calculating the mean squared difference of the X-value over a period of time, which means the total noise in a certain bandwidth near the reference frequency. And this bandwidth is the bandwidth of the digital filter after the PSD, because the noise obtained from different bandwidths is different, so the next normalization process should be performed. The calculated RMS is divided by the square root of the equivalent noise bandwidth of the digital filter ($\sqrt{\text{ENBW}}$), and the resulting noise spectral density is the required measurement value in $\text{V}/\sqrt{\text{Hz}}$. the equivalent noise bandwidth can be calculated by referring to Table 1 in Section 2.5.

2.13 Aux In/Out

There are four 16-bit high-precision AUX-ADC input channels in OE2041. The input voltage ranges from - 10 V to + 10 V, the minimum resolution is 0.1 mV and the sample rate is 312.5ksps. These 4 ADC channels can clamp the input signal and amplify the internal differential signal. The input impedance is 1 M Ω . At the same time, they can pick up signals to measure slow analog signals or DC signals (the signals come from temperature sensor and pressure sensor). This is useful for proportional operation and transferring data to computer.

Because of the internal special structure of the 4 AUX-ADC channels, the measurement result is about 2.048V when the input is floating.

The OE2041 also includes four 16-bit high-precision auxiliary AUX-DAC outputs (interface with DC output CH Output) with ± 10 V output voltage range, minimum resolution of 0.1 mV, and data refresh rate of 1 Msps. Auxiliary voltage outputs can be provided according to user needs.

The AUX IN and AUX OUT connectors are standard BNC connectors integrated into the rear panel of the OE2041. Setting of the AUX-ADC value display is performed in the [DISPLAY] submenu, while setting of the AUX-DAC output value is performed in the [CHOUT AUXOUT] submenu.

2.14 Sweep Frequency and Amplitude of Signal Generator

The OE2041 adds some new functions, such as frequency and amplitude scanning. Signal generator can scan the output amplitude and frequency. Users can sweep the frequency they interested in and analyze the characteristics of the signal. This function greatly increased the actual application

The basic way of frequency and amplitude scanning is setting the value of the start and end point, and increasing the value by step and then the scan is over. See more details in the sections related to frequency and amplitude scanning.

2.15 Multi-harmonic Detection

Harmonics represent waves at multiple frequencies. Periodic function can be described as the linear combination of one constant and many sine or cosine functions with the base frequency and the multiple frequencies. The constant is the DC component. The base frequency component is the base wave. The multiple frequencies are harmonics.

Now many lock-in amplifiers can only measure one base wave or one component of harmonics at one time. But in most practical applications, it is necessary to measure and record multiple harmonics simultaneously. In order to solve this problem, OE2041 realized multi-harmonic detection. Up to 4-channel harmonic components can be measured by one OE2041 at the same time. The OE2041 can do the work that required 4 lock-in amplifiers.

Measurement settings for multi-harmonics are made in the [DEMODO] menu.

In addition to the multi-harmonic measurement function, the OE2041 also adds an arbitrary frequency demodulation function and a formula combination frequency demodulation function.

3. INTERFACES

3.1 Front Panel

The front panel of OE2041 is shown in Fig.8.



Fig.8 Front Panel of OE2041

Display

The OE2041 uses a 5.6 inches TFT-LCD for display and interactive control. Display resolution is 640*480. 8 levels of background brightness are available, which is set in the [SYSTEM] sub-menu. The measurement results are displayed at the left of the screen. It can provide single or double area for display. Otherwise, each area can display number, XY coordinates and polar coordinates. The right of the screen is used to choose and modify control conditions of measurement.

Soft Keys

There are 5 soft keys on the right side of the display screen. The soft keys' functions change with the current menu. In general, these soft keys have two main functions, one is to choose different setting options, and another is to highlight some parameters and then use the knob or keyboard to input. For all functions, soft key only work with parameters that are adjacent to it.

Spin Knob

The knob is used to adjust parameters which are highlighted. Most parameters can be adjusted by the spin knob.

Keyboard

The keyboard consists of 3 groups of buttons. The [ENTRY] area is used to input the highlighted parameters by data forms. The [MENU] area is used to change the parameter list at the right side of the screen. And it provides 10 different function menus. The [ARROW] area provides a selection of certain highlighted parameters, such as Sensitivity range setting, frequency modification for a single bit, etc.

BNC Connectors

There are 6 BNC connectors, from left to right, TTL-OUT, SINE-OUT, ADD-IN, REF-IN, B, A.

SINE OUT	The signal generator can provide programmable voltage which is up to 5 Vrms. The output impedance is 50 Ω . If using the external reference signal, the signal generator can lock the phase of the input signal through PLL.
TTL OUT	The TTL OUT output interface provides a 5V TTL/CMOS compatible square wave signal with an output impedance of 50 Ω at the same frequency as SINE OUT.
ADD IN	The ADD IN function has an input range of -10 V to +10 V. The signal input at this interface can be set to superimpose with the SINE OUT signal.
REF IN	The reference input can be a sine wave or a TTL pulse. When input is a sine wave, the input impedance is 1M Ω AC coupled. For low frequencies (<1Hz), it is necessary to use a TTL reference signal.
SIGNAL IN	There are two signal input modes, single-ended A and differential, A-B. The input A can be current signal. When measuring voltage, the input impedance of A and B are both 50 Ω or 10M Ω /5 pF.

3.2 Rear Panel

The rear panel of OE2041 is shown in Fig.9. It includes a cooling fan, power connector, power switch, USB 2.0 connector, RS-232 female connector, Ethernet connector, Digital-IO connector, and extended function connector. Among them, the extended function interface includes AUX IN, AUX OUT, CLK IN, CLK OUT, SYNC IN, SYNC OUT, and MONITOR.

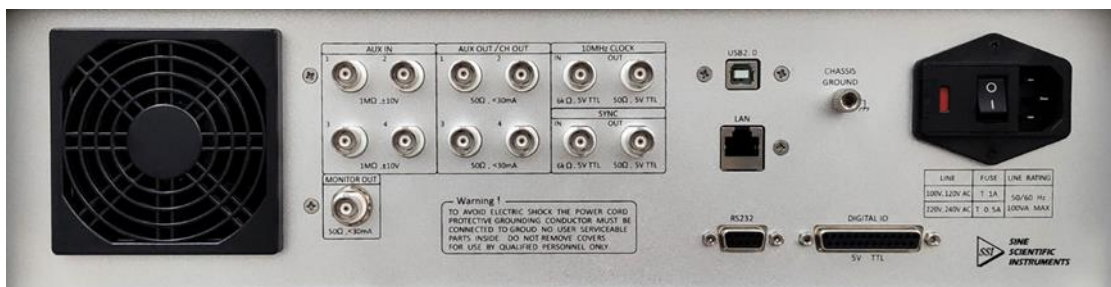

Fig.9 Rear Panel of OE2041

Power Connector Power connector is used to provide power for the instrument. This power connector with a built-in fuse receives 220 V, 50 Hz AC power. And it can filter high frequency noise.

USB2.0	The OE2041 lock-in amplifier communicates with the PC through a USB2.0 interface so that the PC can control the OE2041 and read data.
RS232	The RS232 interface is a standard 9-pin RS-232 female interface that allows the OE2041 to communicate with other host computers.
Ethernet	Ethernet interface communication rate is up to 1000Mbps, can be fast communication with PC.
AUX IN	Four auxiliary AUX-ADC inputs with ± 10 V input range and minimum resolution of 0.1 mV
AUX OUT	Four auxiliary AUX-DAC outputs with ± 10 V output range and minimum resolution of 0.1 mV
CLK IN	CLK IN is the external clock input interface, which can only receive 10MHz, 3.3V level clock signal input for synchronizing clock use with external instruments. Note that if the external clock source is not stable, it will degrade the performance of OE2041.
CLK OUT	CLK OUT provides a 10MHz clock output interface with operating level of 3.3V.
SYNC IN & SYNC OUT	The SYNC IN and SYNC OUT interfaces are used to synchronize between multiple OE2041s.
MONITOR	MONITOR provides an output signal obtained after analog amplification and filtering, i.e., the signal before input to the ADC. Since analog amplification also amplifies noise, the MONITOR output is not suitable for observing signals with very small amplitude of the original signal.

3.3 Main Display

The main display is divided into 4 parts, including Status bars, Function bars, Monitoring bars and Menu bars.

3.3.1 Status Bar

As is shown in Fig.10 and Fig.11, the status bars indicate the current settings of the system

or the result of measurement. Users can switch what to display in the submenu [DISPLAY]. Status bars can show the following parameters:

Specifications at the Status bars:

<Sens>	The value of sensitivity.
<Gain>	The value of input gain.
<R _{IN} >	Input impedance.
<Cpl>	The couple mode.
<Src>	The input mode.
<TC>	The value of time constant.
<Slope>	The value of filter roll off slope.
<Sync>	The setting of synchronous filter.
<Grnd>	A, B connector shields grounding method
<AUX-IN1>	The input amplitude of AUX-IN1 interface.
<AUX-IN2>	The input amplitude of AUX-IN2 interface.
<AUX-IN3>	The input amplitude of AUX-IN3 interface.
<AUX-IN4>	The input amplitude of AUX-IN4 interface.

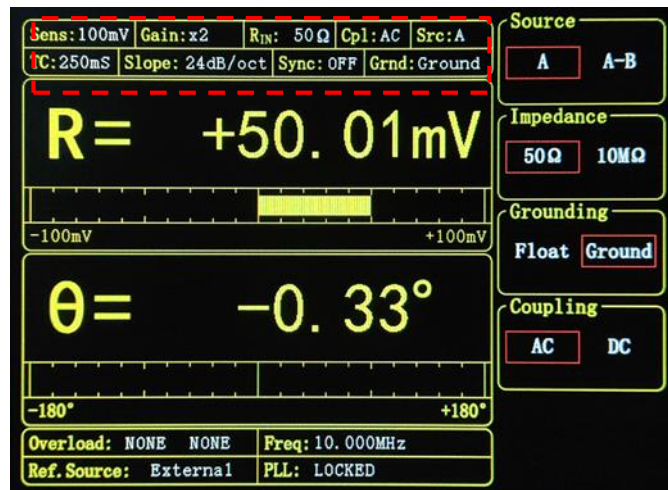

Fig.10 Main Interface: Status Bar 1

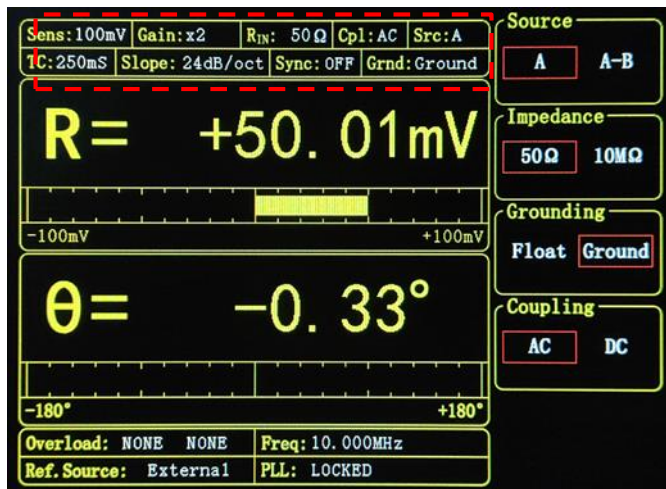

Fig.11 Main Interface: Status Bar 2

3.3.2 Data Bar

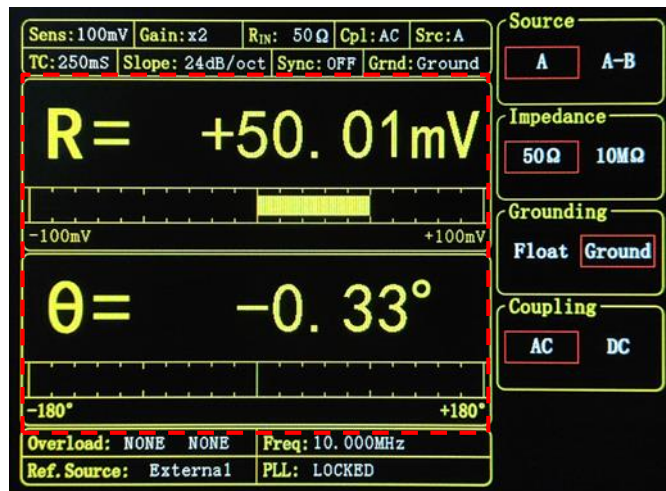

Fig.12 Main Interface: Data Bar

Users can choose which to display among <X>, <Y>, <R>, < θ > in [DISPLAY] submenu, as is shown in Fig.12. How to display is also optional, such as number chart, bar chart, XY coordinate graph and pole coordinate graph. More details about setting is in [DISPLAY] submenu.

3.3.3 Monitoring Bar

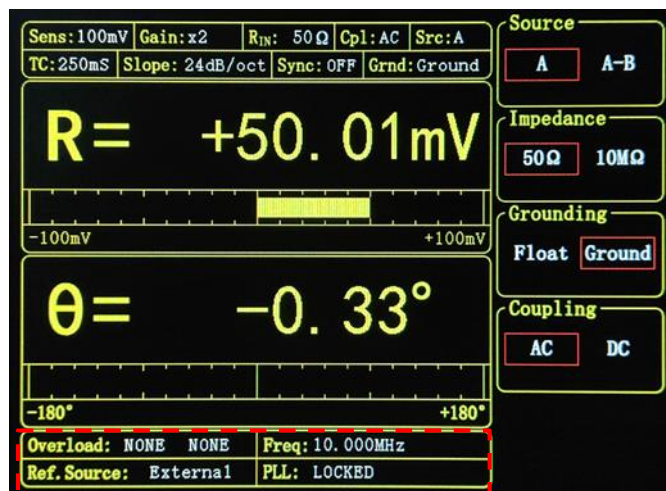

Fig.13 Main Interface: Monitoring Bar

The monitoring bar is on the bottom of the screen as is shown in Fig.13:

<Overload>

To indicate an input overload or amplification overload.

If there is no overload, it shows <Overload: NONE NONE>;

If an input overload, it shows <Overload: INPUT NONE>;

If an amplification overload, it shows <Overload: NONE GAIN>;

If there are both an input overload and amplification overload, it shows <Overload: INPUT GAIN>. In this case, reduce the input as soon as possible to prevent over-voltage damage to the instrument.

- <Freq>** Display the frequency of input signal.
- <Ref. Source>** The mode of the reference signal: Internal or External.
- <PLL>** The status of PLL.
 If the PLL is locked, it shows <PLL: LOCKED>.
 If there is no reference or the PLL is not locked, it shows <PLL: UNLOCKED>.
 If internal reference is used, it always shows <PLL: NONE>.

3.3.4 Function Bar

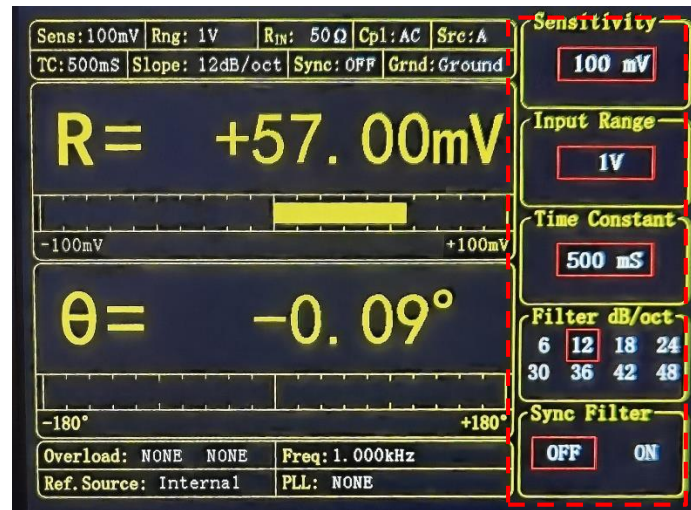

Fig.14 Main Interface: Function Bar

As is shown in Fig.14, users can choose different functions in the function bar. It's operated by 5 soft keys which are make different sense in different submenu. This is the basic way to control the system.

4. MENU

The MENUs consist of ten parts: [INPUT/FILTERS], [REF/PHASE], [GAIN/TC], [DISPLAY], [SAVE/LOAD], [CHANNEL OUTPUT], [SAMPLE], [AUX OUTPUT], [SYSTEM] and [AUTO SET]. Each button has an independent corresponding submenu.

4.1 [INPUT/FILTERS]

When press the [INPUT/FILTERS] button, you will enter this following submenu, as is shown in Fig.15. There are 4 function settings in this submenu, including <Source>, <Impedance>, <Grounding>, and <Coupling>.

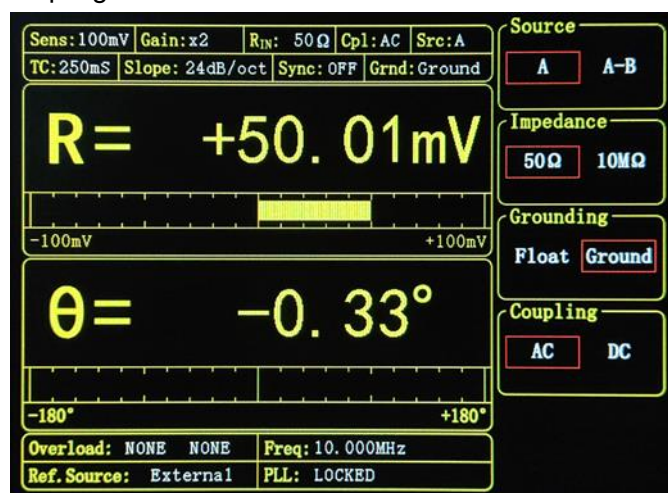

Fig15. [INPUT/ FILTERS] submenu

4.1.1 <Source>: Setting the Input Signal Mode

<A> Single-ended voltage input mode.

<A-B> Differential voltage input mode.

Note that when choose mode <A> and mode <A-B>, the amplitude of the input signal must be less than 1 Vrms.

4.1.2 <Impedance>: Setting the Input Impedance.

<50Ω> The input impedance set to 50Ω.

<10 MΩ> The input impedance set to 10MΩ.

4.1.3 < Grounding >: Setting the Ground Mode

<Float> The connector shields are isolated from the chassis ground by 10kΩ.

<Ground> The connector shields are isolated from the chassis ground by 0Ω and chassis ground is connected to the earth directly.

Generally, choose <Ground> when the current of the input signal is not large. It prevents signal drift caused by floating. Choose <Float> when there is a large potential difference between the

signal ground and chassis ground and a strong current injection. This can limit the current and protect the system circuit.

Note that when measuring weak signals (<1mV), it is recommended to use <Ground> mode, provided that the signal ground and the instrument ground are at the same ground level.

4.1.4 < Coupling >: Setting the Coupling Input Mode

- <AC> AC coupling input mode. In this mode, the DC component of the input signal will be eliminated. If the signal frequency is greater than 10 Hz, <AC> should be chose.
- <DC> DC coupling input. DC coupling does not block any input signal, and it is recommended to use <DC> coupling if the signal frequency is below 10 Hz. However, it is important to pay attention to signal overflow due to the bias amount of the input signal.

4.2 [REF/PHASE]

Press [REF/PHASE] and enter its submenu. There are 5 function settings in the submenu, including <Ref.phase>, <Ref.source>, <Ref.slope>, <Ref.frequency>, and <Sweep>. When choose different <Ref.source>, there will be different submenus as shown in Fig.16, Fig.17 and Fig.18.

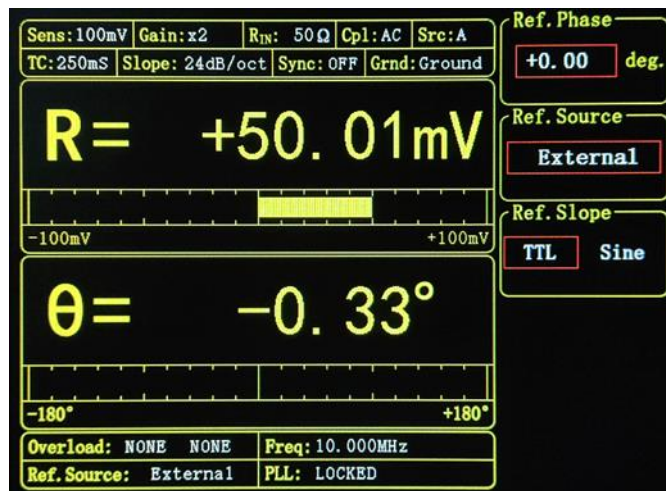

Fig.16 [REF/PHASE] Submenu-<External>.

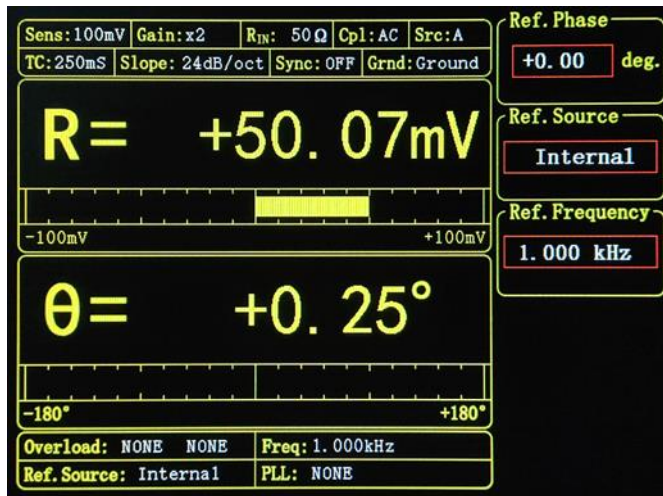

Fig.17 [REF/PHASE] Submenu-<Internal>

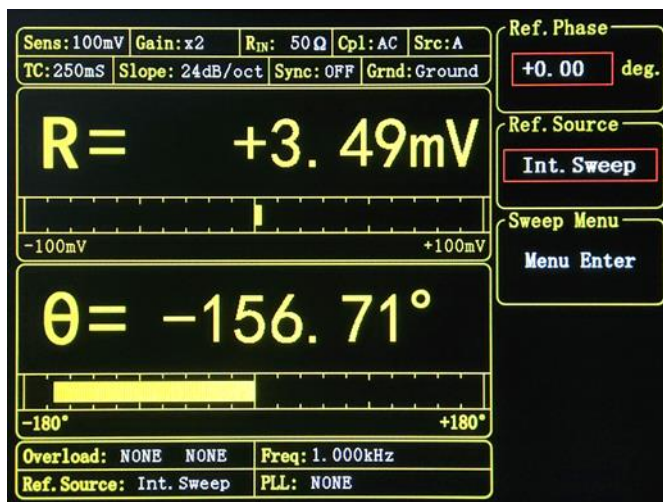

Fig.18 [REF/PHASE] Submenu-<Internal Sweep>

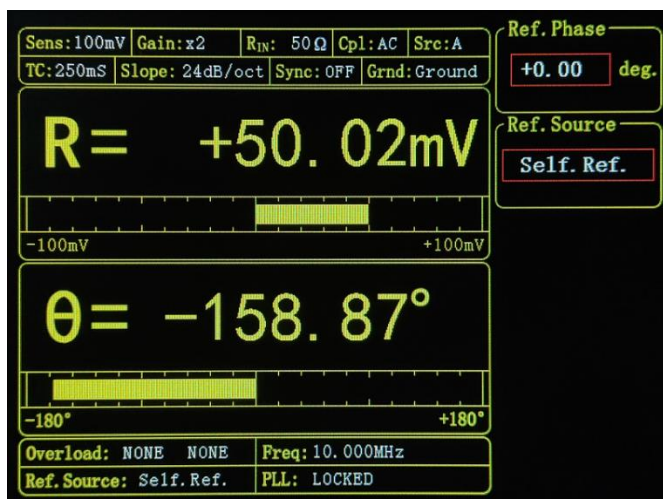

Fig.19 [REF/PHASE] Submenu-<Self.Ref>

4.2.1 < Ref. phase >: Setting the Reference Phase

Users can set the phase shift between two orthogonal reference signals through the keyboard. The accuracy of phase is 0.01° and the range is from -180° to $+180^\circ$.

For phase, it's meaningful only when there is a reference. In the system, the default reference phase is the phase of REF IN after locked by a high precision PLL. Other phases are relative to this reference phase.

4.2.2 < Ref. source>: Setting the Reference Source

- <External> The external reference signal. OE2041 will be phase-locked to the reference signal of the REF-IN BNC input. As is shown in Fig.16, <Ref.slope> can be set.
- <Internal> The internal reference signal. In this mode, the reference signal is from the internal oscillator. The [REF IN] signal is useless. As is shown in Fig.17, <Ref.frequency> can be set.
- <Internal Sweep> The internal reference signal sweep. In this mode, the signal generator will conduct internal sweep according to the parameters set by users. As is shown in Fig.18, <Sweep> can be set.
- <Self.Ref> Self-reference mode. In this setting, OE2041 will use the signal of the input channel (A, A-B) also as the reference signal for phase locking, when the REF-IN interface is invalid. The interface at this point is shown in Figure 19. It should be noted that when the input signal amplitude is too small or the signal-to-noise ratio is low, the phase-locked loop may be unstable, and the <Self.Ref.> mode is not recommended at this time.

4.2.3 < Ref. slope>: Setting the External Signal Mode

When <External> is chosen in <Ref. source>, this setting can access. Choose the corresponding signal type according to the actual external reference signal.

- <TTL> Choose TTL when the external reference signal is a square wave.
- <Sine> Choose Sine when the external reference signal is a sine wave.

If the external reference signal is TTL logic, choose <TTL>. Pay attention that, even if the REFIN is a square wave, it may still obtain an unsteady trigger because the level does not satisfy the threshold condition of the TTL logic. Thus, it is beneficial to choose <Sine> to trigger. Moreover, choose TTL signal if the signal frequency is very low ($<1\text{Hz}$).

If the input reference signal is sine wave, choose SINE to trigger. In this mode, the instrument will do precision truing for the REF IN input and then detect the frequency and phase information.

Otherwise, the system has no requirement on the signal duty cycle no matter what the trigger way is. It is kind to use common 50% duty cycle.

4.2.4 < Ref. frequency>: Setting the Internal Reference Frequency

This setting is available when <Ref.source> is selected as <Internal>, and the frequency range is from 1 mHz to 60 MHz, default 1 kHz. The frequency setting can be entered via the keyboard with a minimum frequency resolution of 1 mHz, and can also be changed individually by using the four arrow keys in the [ARROW] area when <Ref.frequency> is selected. For example, to quickly adjust 1000Hz to 1100Hz, first select the <Ref.frequency> button, then move the cursor to the hundredth digit by using the [→] and [←] buttons, then change the number of the hundredth digit to 1 by using the [↑] and [↓] buttons, and then press the <Enter> button to confirm the operation. As shown in Figure 20.

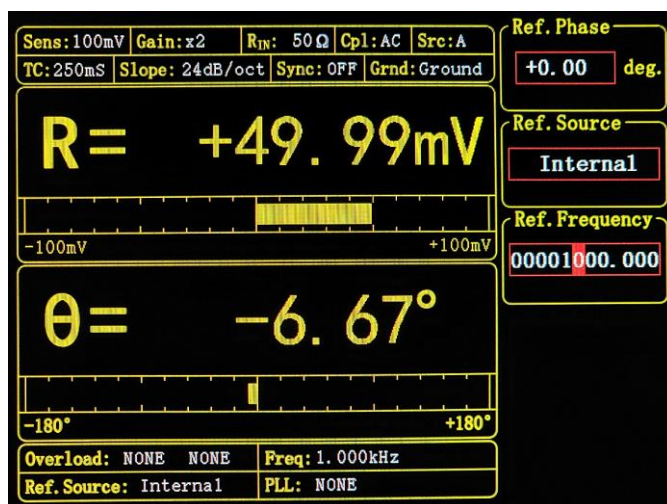

Fig.20 Adjust frequency with [ARROW]

4.2.5 < Sweep>: Setting the Internal Reference Signal Sweep

When < Internal Sweep > is chosen in <Ref. source>, this setting can access. Press the <Sweep> button to access the secondary submenu. In the submenu, users can set <Sweep Type>, <Sweep Set> and <Sweep Run>, as is shown in Fig.21.

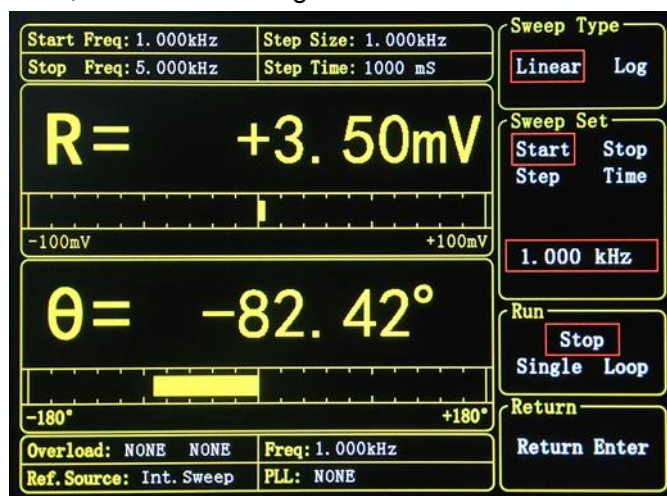

Fig.21 <Sweep> Secondary Submenu

<Sweep Type>	Setting frequency sweep type.
<Linear>	linear sweep type
<Log>	logarithm sweep type

In the <Linear> mode, the step type is frequency by adding the frequency with the setting step frequency. In the <Log> mode, the step type is the percentage of frequency.

For example, in the <Log> sweep mode, the sweep step is 10% of the frequency, the start frequency is 1 kHz and the cutoff frequency is 2 kHz. The process of frequency sweep is:

1000.000 Hz
 1100.000 Hz
 1210.000 Hz
 1331.000 Hz
 1464.000 Hz
 1610.510 Hz
 1771.561 Hz
 1948.717 Hz
 2000.000 Hz

<Sweep Set>	Setting frequency sweep parameters.
<Start>	the start frequency of sweep
<Stop>	the cutoff frequency of sweep
<Step>	in the <Linear> mode, the <Step> is the step frequency; in the <Log> mode, the <Step> is the percentage of frequency.
<Time>	The step time interval of sweep.

Setting the start frequency, cutoff frequency, step frequency and time through keyboard and soft keys. The range of start frequency and cutoff frequency is from 1 mHz to 60 MHz. <Start> frequency is 1.000kHz in default, <Stop> frequency is 5.000kHz and the minimum resolution of the frequency is 1 mHz in default. In the <Log> mode, the minimum resolution of the step is 0.001% of the frequency. In the <Linear> mode, the minimum resolution of the <Step> is 1mHz. In the <Time> mode the minimum/maximum resolution of the step time is 1ms/100,000ms.

<Sweep Run>	Setting frequency sweep running mode
<Stop>	Stop sweep
<Single>	Single sweep
<Loop>	Loop sweep

When start from <Single> sweep, OE2041 does an internal frequency sweep according to the settings of users. After that, the status jumps back to <Stop> automatically.

When start from <Loop > sweep, OE2041 does constant loop sweep until users switch the status to <Stop> manually.

4.3 [GAIN/TC]

Press [GAIN/TC] button, then enter the submenu as is shown in Fig.22. There are 5 function settings in the submenu, including <Sensitivity>, <Input Range>, <Time Constant>, <Filter dB/oct> and <Sync Filter>.

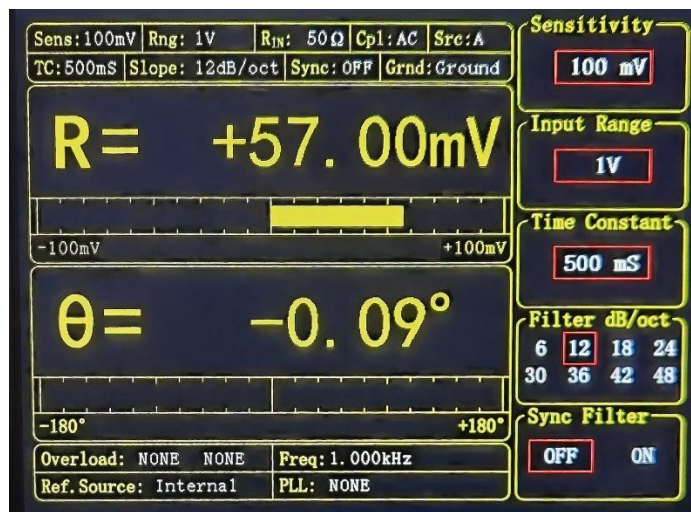

Fig.22 [GAIN/TC] Submenu

4.3.1 <Sensitivity>: Setting the Full Scale Sensitivity

Choose an appropriate full-scale sensitivity according to the amplitude of the input signal. Adjust the value through the soft keys or spin knob. The full scale sensitivity table is shown in Table 2.

Table 2. Full Scale Sensitivity

1 nV/fA	200 nV/fA	50 μV/pA	10 mV/nA
2 nV/fA	500 nV/fA	100 μV/pA	20 mV/nA
5 nV/fA	1 μV/pA	200 μV/pA	50 mV/nA
10 nV/fA	2 μV/pA	500 μV/pA	100 mV/nA
20 nV/fA	5 μV/pA	1 mV/nA	200 mV/nA
50 nV/fA	10 μV/pA	2 mV/nA	500 mV/nA
100 nV/fA	20 μV/pA	5 mV/nA	1 V/μA

The change of <Sensitivity> will change the dynamic range of the system. Besides, it will impact the outputs from CH1 to CH4. The full scale is <100mV> in default.

When choose <Auto Range>, the system will automatically adjust the <Sensitivity> according to R value of input signal. Note that if the time constant is above 1s, the <Auto Range> function is not recommended.

4.3.2 <Input Range>: Setting the Input Range

<1 V > Maximum allowable input 1V signal.

<200 mV >	Maximum allowable input 200 mV signal.
<50 mV >	Maximum allowable input 50 mV signal.
<10 mV >	Maximum allowable input 10 mV signal.
<2 mV >	Maximum allowable input 2 mV signal.
<400 uV >	Maximum allowable input 400 uV signal.

For measurements in general, the gain is selected with no overload in the monitor bar. Selecting a larger magnification without overload will improve the stability of the measurement results.

When choose <Auto Gain>, the system will automatically adjust the maximum gain required according to the R value of input signal to guarantee accuracy of measurement.

<Sensitivity> and <Gain> can be combined into different dynamic reserves, and the relationship is shown in Table 3.

Table 3. Relationship between dynamic reserve and gain

Sensitivity	Dynamic Reserves(dB)						
	Gain=0.4	Gain=2	Gain=8	Gain=40	Gain=200	Gain=600	Gain=1500
1 V	0	-14	-26	-40	-54	-64	-71
500 mV	6	-8	-20	-34	-48	-58	-65
200 mV	14	0	-12	-26	-40	-50	-57
100 mV	20	6	-6	-20	-34	-44	-51
50 mV	26	12	0	-14	-28	-38	-45
20 mV	34	20	8	-6	-20	-30	-37
10 mV	40	26	14	0	-14	-24	-31
5 mV	46	32	20	6	-8	-18	-25
2 mV	54	40	28	14	0	-10	-17
1 mV	60	46	34	20	6	-4	-11
500 μV	66	52	40	26	12	2	-5
200 μV	74	60	48	34	20	10	3
100 μV	80	66	54	40	26	16	9
50 μV	86	72	60	46	32	22	15
20 μV	94	80	68	54	40	30	23
10 μV	100	86	74	60	46	36	29
5 μV	106	92	80	66	52	42	35
2 μV	114	100	88	74	60	50	43
1 μV	120	106	94	80	66	56	49
500 nV	126	112	100	86	72	62	55
200 nV	134	120	108	94	80	70	63
100 nV	140	126	114	100	86	76	69
50 nV	146	132	120	106	92	82	75
20 nV	154	140	128	114	100	90	83
10 nV	160	146	134	120	106	96	89
5 nV	166	152	140	126	112	102	95

2 nV	174	160	148	134	120	110	103
1 nV	180	166	154	140	126	116	109

4.3.3 < Time Constant >: Setting the Time Constants

The range of time constant is from 30 ns to 4400k s. Adjust the value through soft keys and spin knob. The time constant table is shown in Table 4.

Table 4. Time Constants

30 ns	32 us	32 ms	35 s
60 ns	65 us	65 ms	70 s
125 ns	125 us	125 ms	140 s
250 ns	250 us	250 ms	275 s
500 ns	500 us	500 ms	550 s
1 us	1 ms	1 s	1100 s
2 us	2 ms	2 s	2200 s
4 us	4 ms	4 s	4400 s
8 us	8 ms	8 s	
16 us	16ms	17 s	

The greater the time constant, the smaller the ENBW, the longer the system response and the higher the measurement accuracy.

4.3.4 < Filter dB/oct >: Setting the Roll off Slope of the Low Pass Filter

<6dB/oct>	First-order low pass filter, and the roll off slope is 6 dB/oct.
<12dB/oct>	Second-order low pass filter, and the roll off slope is 12 dB/oct.
<18dB/oct>	Third-order low pass filter, and the roll off slope is 18 dB/oct.
<24dB/oct>	Fourth-order low pass filter, and the roll off slope is 24 dB/oct.
<30dB/oct>	Fifth-order low pass filter, and the roll off slope is 30 dB/oct.
<36dB/oct>	Sixth-order low pass filter, and the roll off slope is 36 dB/oct.
<42dB/oct>	Seventh-order low pass filter, and the roll off slope is 24 dB/oct.
<48dB/oct>	Eighth-order low pass filter, and the roll off slope is 24 dB/oct.

At the same measurement accuracy, a greater roll off slope can reduce the time constant, making a faster response. The specific time constants and filter roll off slope must be chosen according to the actual situation. A judgment guideline is that as long as the stability of the measurement results is satisfied, the time constants and filter roll off slope does not need to be set too large at this time to avoid long waiting times. Of course, if you want to have smoother results, you can increase the time constant and filter roll off slope appropriately.

4.3.5 < Synchronous >: Setting the Status of the Synchronous Filter

- <OFF> Turn off the synchronous filter.
- <ON> Turn on the synchronous filter. It's useful at a low reference frequency (< 200 Hz). When the input signal frequency is very low, the low pass filter can't get stable results or it needs a long time to do that. At this time, synchronous filter helps. The effect is shown in Fig.23.

Synchronous filters can effectively remove signals at the reference frequency and its harmonics, reducing the requirement for low-pass filters.

Note that if the synchronous filter is open, <Filter dB/oct> must be <18 dB/oct> or more to really work!

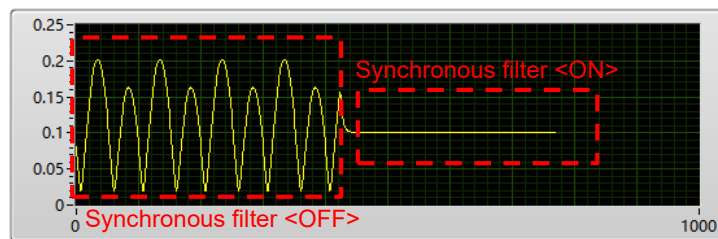

Fig.23 The effect of open synchronous filter.

4.4 [DEMODO]

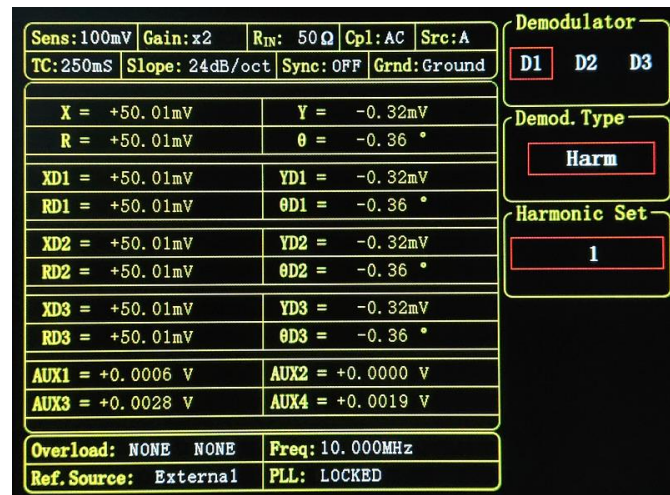

Fig.25 [DEMODO] Submenu

Press [DEMODO] button and enter the submenu as is shown in Fig.25. In this submenu, there are 5 function settings: <Demodulator>, <Demod.Type>, <Harmonic Set>, <Frequency Set> and <Equation Set>. They can be chosen and set by the soft keys beside the submenu.

4.4.1 < Demodulator >: Setting the Choice of Demodulator

OE2041 has 3 additional demodulators D1, D2 and D3 in addition to the demodulator of the reference frequency. The function of each demodulator can be set individually by selecting each demodulator separately via <Demodulator>.

4.4.2 < Demod.Type >: Setting the Mode of Demodulator

- <Harm> Set the current demodulator to harmonic demodulation mode. The interface of this mode is shown in Fig.24.
- <Arb_Freq> Set the current demodulator to any frequency demodulation mode. The interface of this mode is shown in Fig.25.
- <Equation> Set the current demodulator to formula combination frequency demodulation mode. The interface of this mode is shown in Fig.26.

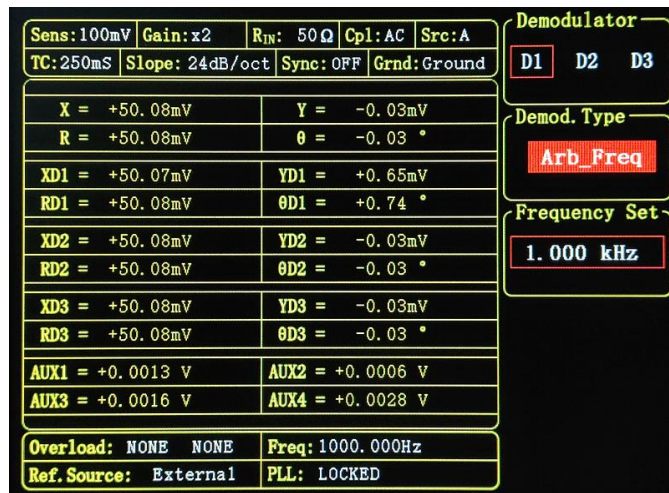

Fig.25 The interface of <Arb_Freq> mode



Fig.26 The interface of <Equation> mode

< Harmonic Set >: Setting the Order of Harmonic Demodulation

This item can be set when <Demod.Type> is set to <Harm>. Its setting range is an integer from 1 to 32767. The harmonic order to be measured is entered via the numeric keyboard, and the default display is 1, which means the 1st order harmonic (i.e. fundamental) is detected. The limit of <Harmonic Set> harmonic order setting is $(\text{Harmonic} \times \text{Freq}) \leq 60\text{MHz}$, where Freq indicates the reference signal frequency. Once the limit is exceeded, the system will automatically adjust the harmonic order downward until the condition is satisfied. Also, when set to 0, the system automatically changes to 1.

For example, if the input signal is a square wave with a frequency of 1 kHz, assume that its peak-to-peak value is A. When the <Harmonic Set> values are set to 1, 2, 3, 4, 5, 6, you will expect to get R values of 0.45A, 0, 0.15A, 0, 0.09A, 0, and this sequence is exactly the A times of the coefficient sequence of the Fourier series of the square wave signal.

Note: Simultaneous display of multi-demodulator measurements requires <Full> to be selected from the <Display Mode> option in the [DISPLAY] submenu, as detailed in the [DISPLAY] submenu.

< Frequency Set >: Setting the Reference Frequency of Demodulator

This item can be set when <Demod.Type> is set to <Arb_Freq>. This setting is the same as the rule of 4.2.4 <Ref.frequency>. When <Arb_Freq> is set to a certain frequency, the demodulator demodulates the signal with that frequency as the reference frequency.

This mode is especially useful when the input signal contains multiple frequency information and the user needs to extract it separately.

< Equation Set >: Setting Formula Combination

This item can be set when <Demod.Type> is set to <Equation>. The formula for <Equation> is:

$$\text{Equation} = A \times F1 + B \times F2$$

A and B are integers, which can be set in the range of -32767 to +32767; F1 and F2 are frequency settings with the same rules as <Ref.frequency>.

If the result of Equation calculation is 1500Hz, then the demodulator is using 1500Hz as the reference frequency for the phase sensitive detection algorithm. This mode has better effect in AM and FM demodulation.

4.5 [DISPLAY]

Press [DISPLAY] button and enter the submenu as is shown in Fig.27.

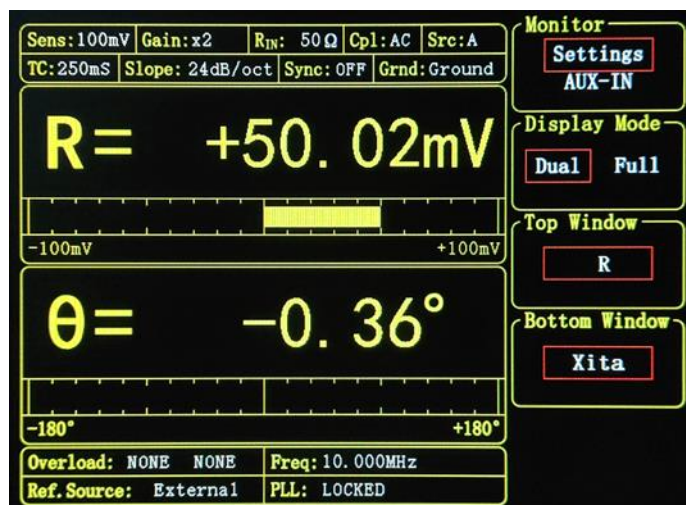

Fig.27 [DISPLAY] Submenu

The [DISPLAY] submenu mainly includes <Monitor>, <Display Mode>, <Top Window>, <Bottom Window> and <Full Window>, which can be selected and set by the corresponding softkeys next to the submenu.

4.5.1 < Monitor >: Setting the Display of Status Bar

- <Settings> In the status bar at the top left of the LCD screen, 9 currently set parameters and status such as <Sensitivity> and <Filter> are displayed.
- <AUX-IN> The real-time input amplitude of the four BNCs of the current rear panel AUX-IN is displayed in the status bar at the top left of the LCD. The interface is shown in Figure 28.

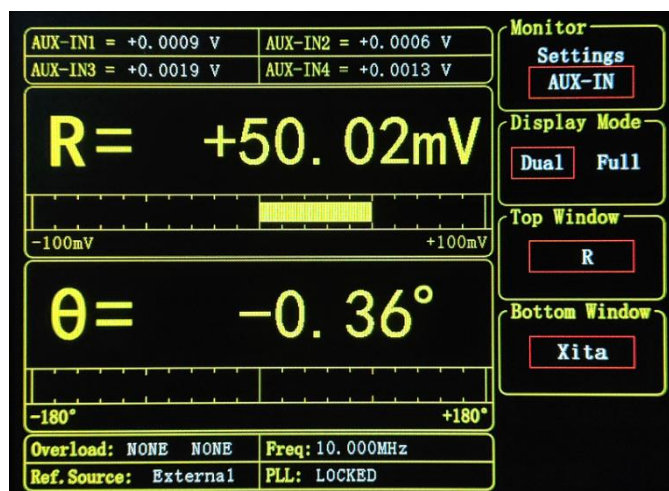

Fig.28 <AUX-IN> Interface

4.5.2 < Display Mode >: Setting the Display Mode of Dynamic Area

The <Display Mode> option is mainly used to set the display type of the data field, and there are two types.

- <Dual> The top and bottom columns are displayed in a separate mode.
This mode is shown in Fig.27.
- <Full> A mode in which all measurement data are displayed in one window.
This mode is shown in Fig.29.

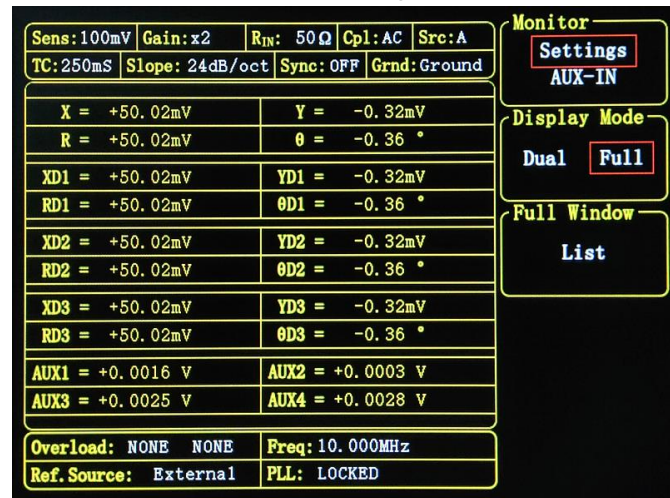

Fig.28 <Full> Display mode

4.5.3 <Top Window>&<Bottom Window>: Setting the Column Window Display Content

When <Display Mode> is set to <Dual>, these 2 options can be set to the following parameters.

- <X> The X value of fundamental wave of the input signal.
- <Y> The Y value of fundamental wave of the input signal.
- <R> The R value of fundamental wave of the input signal.
- <θ> The θ value of fundamental wave of the input signal.
- <X-Noise> The X-Noise value of fundamental wave of the input signal.
- <XD1> The X value of 1st demodulator harmonic of the input signal.
- <YD1> The Y value of 1st demodulator harmonic of the input signal.
- <RD1> The R value of 1st demodulator harmonic of the input signal.
- <θD1> The θ value of 1st demodulator harmonic of the input signal.
- <XD2> The X value of 2nd demodulator harmonic of the input signal.
- <YD2> The Y value of 2nd demodulator harmonic of the input signal.
- <RD2> The R value of 2nd demodulator harmonic of the input signal.
- <θD2> The θ value of 2nd demodulator harmonic of the input signal.
- <XD3> The X value of 3rd demodulator harmonic of the input signal.
- <YD3> The Y value of 3rd demodulator harmonic of the input signal.
- <RD3> The R value of 3rd demodulator harmonic of the input signal.
- <θD3> The θ value of 3rd demodulator harmonic of the input signal.

The upper and lower display windows allow flexible selection of what to display. The default is to display <R> and <θ> values.

4.6 [SINE/OUT]

Press [SINE/OUT] button and enter the submenu as is shown in Fig.30.



Fig.30 [SINE/OUT] Submenu

This submenu includes 5 function settings: <Add Mode>, <Output Mode>, <Voltage>, <Sweep Set> and <Run>.

OE2041 can output sine wave signals with amplitude from 1 uVrms to 1 Vrms through the "Sine Out" BNC connector on the front panel, and three different modes can be set through the submenu: <Fixed> fixed amplitude output, <Linear> linear sweep output, or <Log> logarithmic sweep output. different modes.

When using <External> external reference, <Sine Out> provides a sine signal that is phase-locked to the external reference; when using <Internal> internal reference, the signal is generated by OE2041's own oscillator. At the same time, the BNC header of "TTL OUT" on the front panel will output a TTL signal with the same frequency as <Sine Out>.

4.6.1 < Add Mode >: Setting the ADD IN Interface

<OFF> Unable ADD IN interface function.

<ON> Enable ADD IN interface function.

This function can be enabled when the reference frequency is below 10MHz. When enabled, it is superimposing the Sineout signal and the ADD IN signal. If the Sineout setting is a 100mV sine wave and the ADD IN interface inputs a 1V DC signal from outside, then the final Sineout signal will become a 1V DC biased sine wave with an AC amplitude of 100mV.

4.6.2 < Output Mode >: Setting the Output Mode

<OFF>	Turn off Sineout output, in this mode Sineout constant output 0V.
<Fixed>	Fixed AC amplitude output mode.
<Linear>	Linear sweep output mode.
<Log>	Log sweep output mode.

At times, it is recommended to turn off the Sineout output during extremely weak signal measurements (e.g. resistance thermal noise measurements) to reduce the effect of co-channel interference within the system.

When <Fixed> mode is selected, Sineout outputs a sine wave signal with a stable amplitude.

When <Linear> mode is selected, the step type is linear accumulation, and the amplitude is accumulated with the set step amplitude. In <Log> mode, the step type is a percentage increment of the amplitude.

For example, in <Log> sweep mode, the sweep step is 10%, the start frequency is 100mVrms, the cutoff frequency is 200mVrms, and the sweep process is as follows:

100.000mVrms → 110.000mVrms → 121.000mVrms → 133.100mVrms → 146.410mVrms
→ 161.051mVrms → 177.156mVrms → 194.872mVrms → 200.000mVrms

< Voltage >: Setting the Amplitude of Sine Output

Sine signal amplitude setting in fixed AC amplitude mode <Fixed>, input via numeric keypad and knob, range 1uVrms~1Vrms rms, minimum resolution 1 uVrms.



Fig.31 <Voltage> Menu

< Sweep Set >: Setting the Parameters of Sweep Amplitude

This menu can be set when <Output Mode> is set to <Linear> and <Log>. At this time, the interface is shown in Fig.32.

< Start > Start amplitude of sweep.

- < Stop > Stop amplitude of sweep.
- < Step > When <Linear> is the step amplitude of the sweep, when <Log> is the percentage.
- < Time > Step time interval of sweep.

The start amplitude, cutoff amplitude, step and time settings in sweep mode are set by numeric keypad with soft keys. The amplitude range is from 1 uVrms to 1 Vrms, the default <Start> start amplitude is 1.000 Vrms, <Stop> stop amplitude is 1.000 Vrms, the resolution of amplitude is minimum 1 uVrms; the resolution of <Step> is minimum 0.001 % for <Log>, <Step> resolution is minimum 1 for <Linear>. uVrms; <Time> resolution is minimum 1 ms, maximum 100,000 ms.

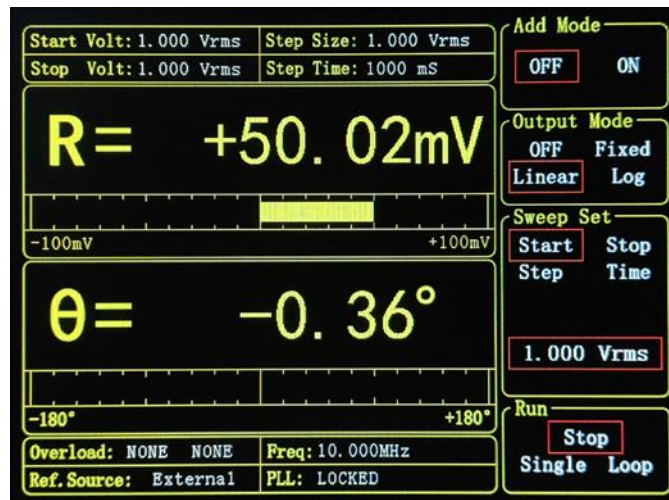

Fig.32 <Sweep Set> Menu

<Offset> setting: It is set through keyboard. The adjustable range is -100%~+100%. The minimum step is 0.01% and 0.00% is default.

<Expand> setting: It is set through keyboard. The adjustable range is 1~256 and 1 is default. If the setting value of Expand causes the calculation result over ±10V, the output will be seriously affected.

The settings of <Offset> and <Expand> will not affect the data display in dynamic area.

< Run >: Setting the Operation Mode of Sweep Amplitude

- < Stop > Stop sweep amplitude.
- < Single > Single sweep amplitude.
- < Loop > Loop sweep amplitude.

When <Single> single sweep is started, OE2041 performs one sweep of amplitude according to the user's setting, and then the status automatically jumps back to <Stop> to stop sweeping after completion.

When <Loop> cyclic sweep is started, OE2041 keeps cyclic sweeping according to the user's design until the user manually changes the status to <Stop> to stop sweeping.

4.7 [AUTO SET]

The [AUTO SET] submenu includes 3 automatic settings in OE2041. As shown in Fig.33.

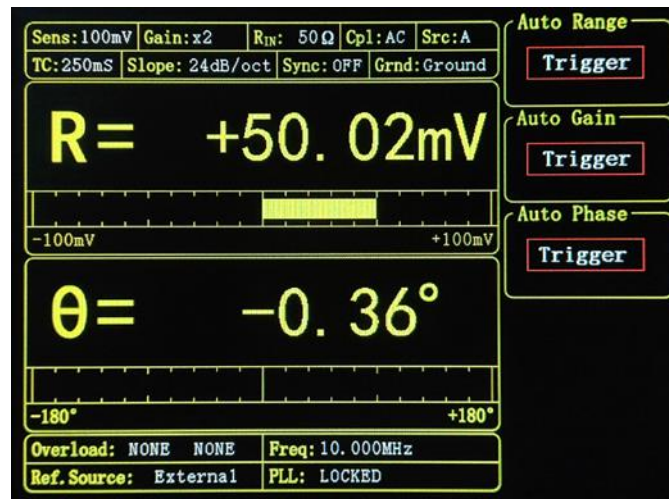

Fig.33 [AUTO SET] Submenu

4.7.1 < Auto Range >: Automatically Setting Measurement Range

When the <Auto Range> button is pressed, the system automatically changes the <Sensitivity> setting according to the amplitude of the signal. The principle is to select the setting that measures the maximum dynamic reserve of the current signal.

4.7.2 < Auto Gain >: Automatically Setting Input Gain

When the <Auto Gain> button is pressed, the system will automatically change the <Gain> setting according to the signal amplitude, the principle is to select the maximum input gain <Gain> without overloading the instrument itself. The <Auto Gain> function of OE2041 requires a certain response time (generally less than 5 seconds), if the current R value fluctuates greatly, or if the current R value fluctuates greatly, or if the time constant is greater than 1s, the <Auto Gain> setting may not be successful. In this case, please switch to the [GAIN/TC] submenu for manual setting.

4.7.3 < Auto Phase >: Automatically Setting Phase Adjustment

When the <Auto Phase> button is pressed, the OE2041 will adjust the phase shift of the reference signal so that the measured input signal phase is 0° . This function requires a certain response time (usually less than 5 seconds), and if the current theta value fluctuates greatly, the <Auto Phase> setting may not be successful. In this case, please switch to [REF/PHASE] submenu to set <Phase> value manually.

4.8 [CHOUT/AUXOUT]

Accessed by selecting the [CHANNEL OUTPUT] submenu in the menu bar of the front panel, as shown in Fig.34.

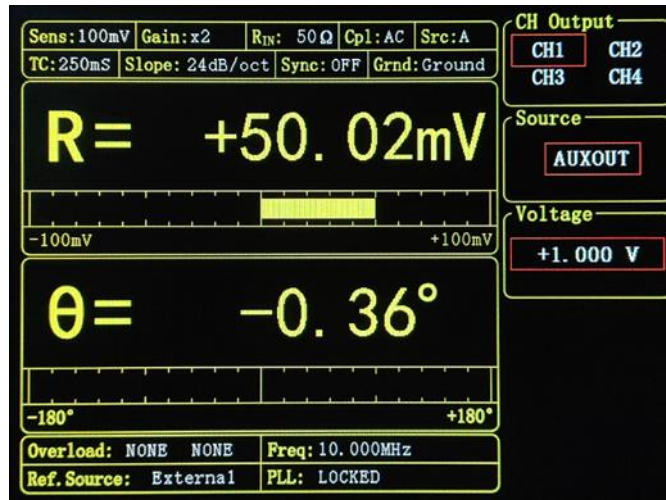

Fig.34 [CHOUT/AUXOUT] Submenu

The [CHOUT/AUXOUT] submenu controls the 4 BNC channels of AUXOUT / CHOUT on the rear panel, which can output any value, R, X, Y and θ values, etc. that the user needs, as well as set the output bias and amplification via <Offset&Expand>. The output data rate of the channels is also set in the <Speed> option.

The output signal is calculated as follows:

1. When the selected signal is <R>, <X>, <Y>, <RD1>, <XD1>, <YD1>, <RD2>, <XD2>, <YD2>, <RD3>, <XD3>, <YD3>, <X-Noise>:

$$\text{Output} = \left(\frac{\text{Signal(selected)}}{\text{Sens}} + \text{Offset} \right) \times \text{Expand} \times 10V$$

2. When the selected signal is 为<θ>, <θD1>, <θD2>, <θD3>:

$$\text{Output} = \frac{\text{Signal(selected)}}{180^\circ} \times 10 V$$

3. In addition to the above two cases, the following options are available:
 - a) AUXOUT : Output according to the user-set voltage value.
 - b) ADC1~ADC4 : Output is equal to the input voltage of AUX-IN.
 - c) Freq :

Each step of the frequency is divided into 5 V-10 V, for example:

- 1000Hz = 5 V
- 1200Hz = 6 V
- 1600Hz = 8 V
- 1800Hz = 9 V
- 1990Hz = 9.95 V
- 2000Hz = 5 V (Next step)

Step is defined as:

...
 62.5 Hz– 125 Hz
 125 Hz – 250 Hz
 250 Hz – 500 Hz
 500 Hz – 1000 Hz
 1 kHz – 2 kHz
 4 kHz – 8 kHz
 8 kHz – 16 kHz
 ...

4.8.1 < CH Output >: Setting the CH channel choice

Select the channel configuration of CH1 to CH4 separately, and each channel can select an output source separately.

4.8.2 < Source >: Setting the Output Source of Channels

<AUXOUT>	The channel outputs set level. Each CH channel has a separate <AUXOUT> parameter.
<X>	The channel outputs analog level corresponding to X value.
<Y>	The channel outputs analog level corresponding to Y value.
<R>	The channel outputs analog level corresponding to R value.
< θ >	The channel outputs analog level corresponding to θ value.
<XD1>	The channel outputs analog level corresponding to XD1 value.
<YD1>	The channel outputs analog level corresponding to YD1 value.
<RD1>	The channel outputs analog level corresponding to RD1 value.
< θ D1>	The channel outputs analog level corresponding to θ D1 value.
<XD2>	The channel outputs analog level corresponding to XD2 value.
<YD2>	The channel outputs analog level corresponding to YD2 value.
<RD2>	The channel outputs analog level corresponding to RD2 value.
< θ D2>	The channel outputs analog level corresponding to θ D2 value.
<XD3>	The channel outputs analog level corresponding to XD3 value.
<YD3>	The channel outputs analog level corresponding to YD3 value.
<RD3>	The channel outputs analog level corresponding to RD3 value.
< θ D3>	The channel outputs analog level corresponding to θ D3 value.
<X-Noise>	The channel outputs analog level corresponding to X-Noise value.
<Y-Noise>	The channel outputs analog level corresponding to Y-Noise value.
<Freq>	The channel outputs analog level corresponding to Freq value.
<ADC1>	The channel outputs analog level corresponding to AUX-IN1 interface.
< ADC2>	The channel outputs analog level corresponding to AUX-IN2 interface.
< ADC3>	The channel outputs analog level corresponding to AUX-IN3 interface.
< ADC4>	The channel outputs analog level corresponding to AUX-IN4 interface.

4.8.3 < Offset&Expand >: Setting the Offset and Expand

When a source other than <AUXOUT> is selected, such as <X>, <Y>, <R>, etc., the options menu of <Offset>, <Expand> and <Speed> will appear, and the interface is shown in Fig.35.

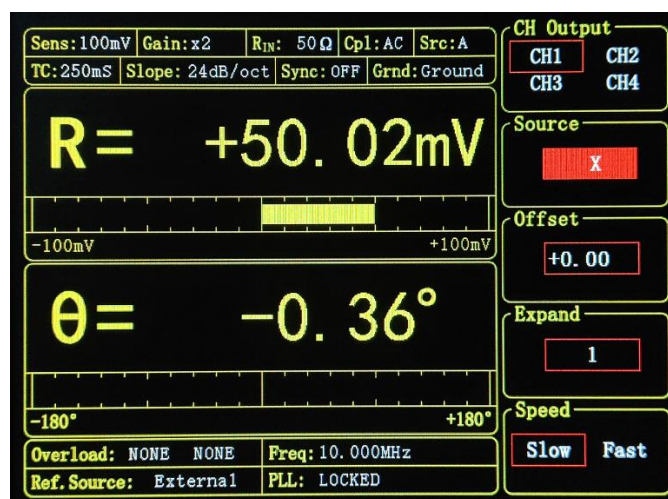

Fig.35 <Offset&Expand> Interface

<Offset> Offset setting.

Input via numeric keyboard, adjustable range is -100%~ +100%, where the minimum step is 0.01%, default 0.00%.

<Expand> Zoom setting.

Input via numeric keyboard, adjustable range is 1~256, default value is 1. However, the Expand setting makes the output value will be maintained at $\pm 10V$ when the calculation exceeds $\pm 10V$.

Note: Each CH channel has an independent bias value and amplification value. If the <Offset> of CH1 is set to 50% and the <Expand> is set to 3, only the output of CH1 will be affected, while the output of CH2, CH3 and CH4 will remain unchanged.

Note: The setting of <Offset> and <Expand> will not affect the data display in the dynamic area data frame.

4.8.4 < Speed >: Setting the Output Speed

- <Slow> The data update rate for channel outputs CH1 & CH2 is 10 Hz.
- <Fast> The data update rate of channel outputs CH1 & CH2 is 1 MHz.
Only 12 data sources <X>, <Y>, <R>, <XD1>, <YD1>, <RD1>, <XD2>, <YD2>, <RD2>, <XD3>, <YD3> and <RD3> can be selected at this setting.

Note: This setting is not valid for <AUXOUT> data sources, and the update rate is fixed at 10Hz for <AUXOUT> data sources.

4.9 [SYSTEM]

[SYSTEM] submenu includes the system information and settings of OE2041, like instrument information, screen brightness and the settings of communications, as is shown in Fig.36.

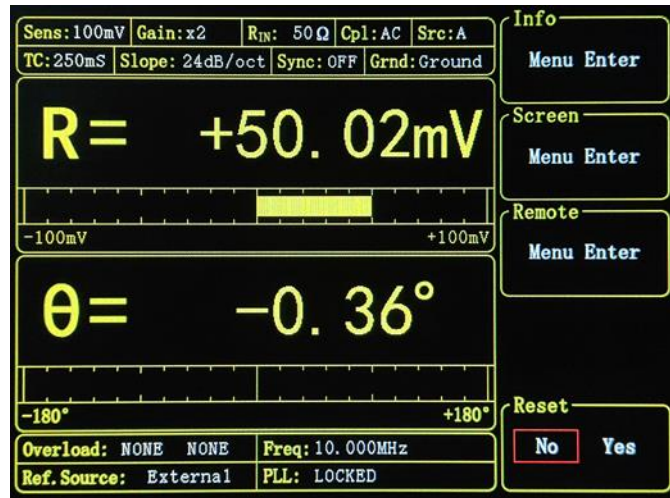

Fig.36 [SYSTEM] Submenu

4.9.1 < Info > Secondary Submenu

Select <Info> secondary submenu to enter, the interface displays information of R&D unit, after-sales contact, product serial number, version number and other information, as shown in Fig.37. Among them, the serial number should be consistent with the factory label on the rear panel.

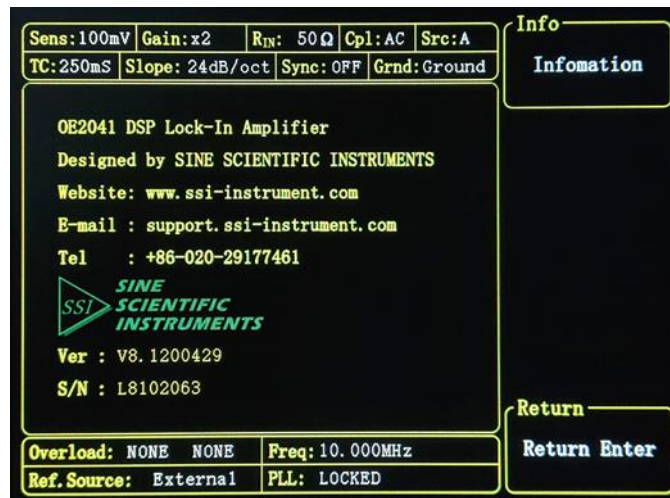

Fig.37 <INFO>-Submenu

4.9.2 <Screen> Secondary Submenu

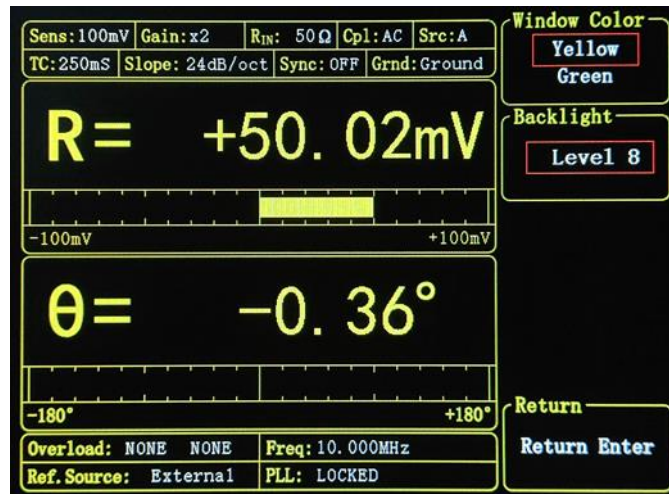

Fig.38 <Screen> Submenu-<Yellow> Style

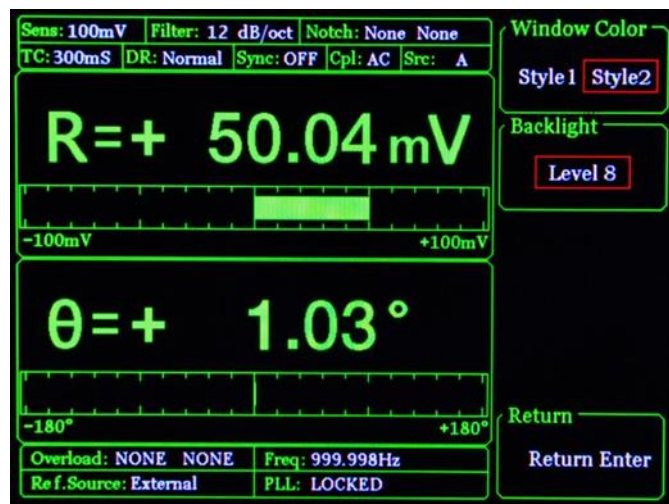

Fig.39 <Screen> Submenu-<Green> Style

Choose <Screen> to enter this interface, as is shown in Fig.38 and Fig.39.

This submenu includes two function settings, <Window Color> and <Backlight>.

<Window Color> Setting the window color.

 <Yellow> The window main color is yellow, as is shown in Fig.38.

 <Green> The window main color is green, as is shown in Fig.39.

<Backlight> Setting the brightness of backlight.

With the knob adjustment, the brightness level can be adjusted from <Level1> to <Level8>, corresponding to the brightness from low to high, and the default is <Level8>.

4.9.3 < Remote > Secondary Submenu

Choose the <Remote> secondary submenu to enter Fig.38.

OE2041 has 3 kinds of remote communication interfaces, RS232 serial port, USB2.0 high-speed interface, and Ethernet interface, but only 1 kind of communication interface can be used at the same time, depending on the interface selected by <Remote Mode>.



Fig.40 <Remote> Submenu-<RS232> Option

< Remote Mode >: Selecting the Remote Interface

- <RS232> RS232 serial communication interface for DB9 female interface.
The configuration interface is shown in Fig.40.
- <USB2.0> USB2.0 high-speed communication interface.
The configuration interface is shown in Fig.41.
- <Ethernet> 1000Mbps Ethernet interface.
The configuration interface is shown in Fig.42.

When one of the remote communication interfaces is selected, OE2041 can only communicate on that interface and the configuration menu for the current interface will be displayed.

The factory-supplied PC-based remote control software is based on USB 2.0.

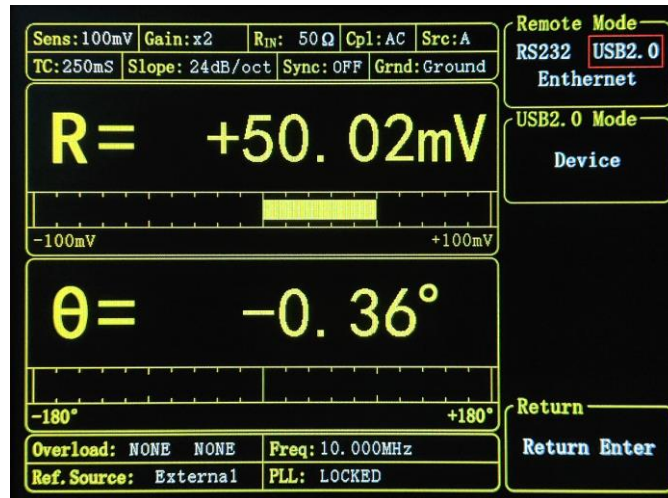

Fig.41 <Remote> Submenu-<USB2.0> Option

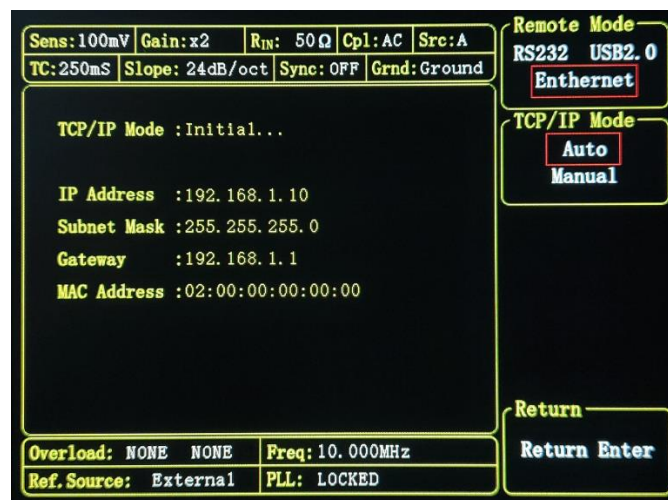

Fig.42 <Remote> Submenu-<Ethernet> Option

< Baud Rate >: Setting the Baud Rate

This option is visible in <RS232> mode.

Press the corresponding soft keys or spin knob to adjust the baud rate. The value can be set as <600>, <1200>, <2400>, <9600>, <19200>, <38000>, <43000>, <56000>, <57600>, <115200>, <230400>, <460800> and <921600>.

< Parity Check >: Setting the Parity Check

This option is visible in <RS232> mode.

- <Even> Even Check.
- <Odd> Odd Check.
- <None> No Check.

< TCP/IP Mode >: Setting the Ethernet TCP/IP Mode

This option is visible in <Ethernet> mode. Normally, after connecting the network cable, you can connect to the LAN automatically with <Auto> mode.

- <Auto> Automatically configure TCP/IP protocols.
- <Manual> Manually configure TCP/IP protocols.

When in <Auto> mode, it will first initialize as shown in Fig.42. When network access is detected, it will jump to the status of "Connecting..." in Fig.43, indicating that it is connecting to the current network. When the network is successfully connected, the local IP address, subnet mask, gateway and local mac address of the current network will be displayed as shown in Fig.44.

When in <Manual> mode, you can manually configure the IP address, subnet mask and gateway of TCP/IP protocol, as shown in Fig.45. Select the IP, subnet and Gateway to be modified in the <IP Select> window, and then press the <Excute> button to enter the parameters to be configured in the numeric keyboard area, as shown in Fig.46, and finally press <ENTER> to confirm.

When the configuration is finished, you can configure and read data from OE2041 in the LAN.



Fig.43 <Auto> Mode - Connecting

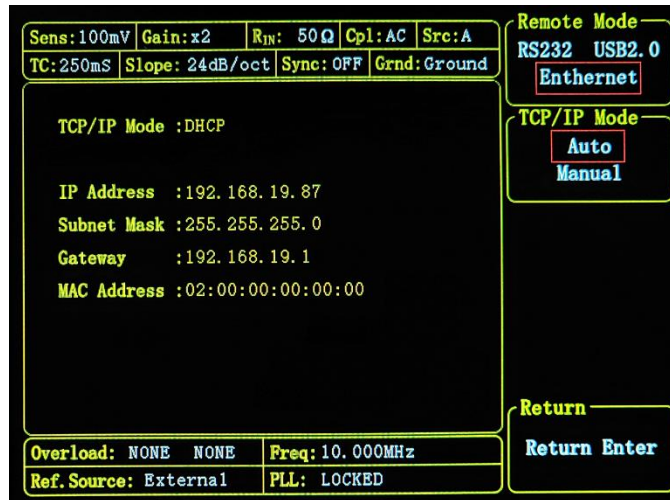

Fig.44 <Auto> Mode – Connection successful

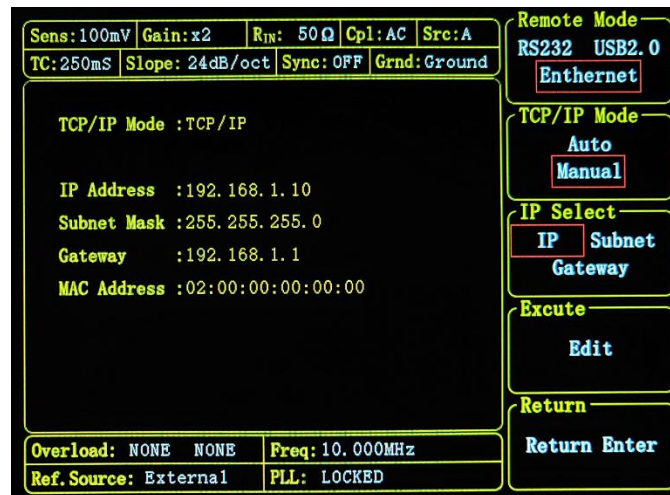

Fig.45 <Manual> Mode

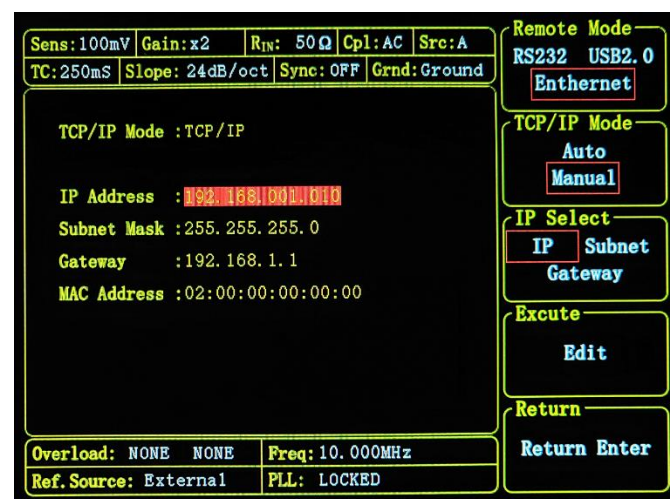

Fig.46 <Manual> Mode - Modifying

4.9.4 < Reset >: The Lock-in Reset

Press the corresponding soft key and the system will be restarted. The current settings are not changed after restart

4.10 [SAVE/RECALL]

Select the [SAVE/RECALL] submenu from the menu bar on the front panel to access it, as shown in Fig.47.

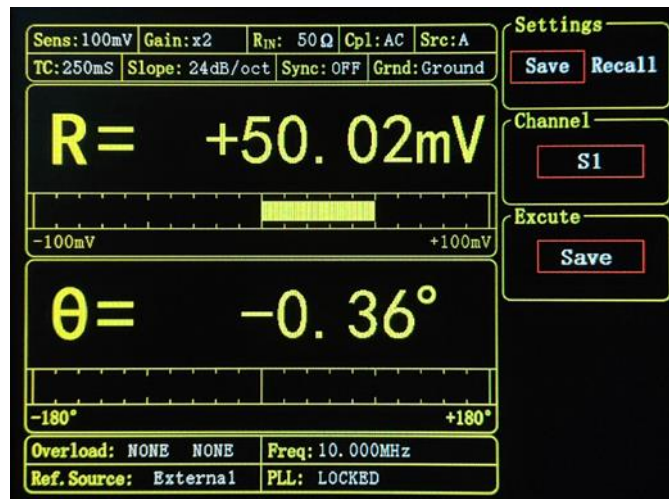

Fig.47 [SAVE/RECALL] Submenu

The [SAVE&RECALL] menu is mainly used to save and recall the parameters and states that have been set. Depending on the user's preference, 4 archives can be saved in the item <S1>, <S2>, <S3> and <S4>. As shown in Fig.47, select <Save>, <Channel> select <S1>, and then <Save> in the <Execute> item to save the currently set parameters and states in the <S1> archive. To read this archive, simply select <Recall>, then <Channel> select <S1>, and then <Execute> select <Call>.

In <Recall> state, <Channel> has <Default> option to restore the entire machine configuration to default values.

5. REMOTE PROGRAMMING

5.1 OE2041 Command Syntax

Computers use ASCII characters to communicate with OE2041. Commands must be in upper case. A command consists of a four-character command mnemonic, arguments if necessary, and a command terminator. When communicating using RS232, USB 2.0, or Ethernet interfaces, the terminating character must be a semicolon <;>, and a carriage return <cr>. No command processing occurs until a command terminator is received. Commands may require one or more parameters. Multiple parameters are separated by commas (,).

Multiple commands may be sent on one command line by separating them with semicolons (;). The difference between sending several commands on the same line and sending several independent commands is that when a command line is parsed and executed, the entire line is executed before any other device action proceeds.

The OE2041 has a 256-character input buffer and processes commands in the order received. If the buffer fills up, the new commands will cover the oldest and processed commands. It is recommended that when users enter multiple commands, the commands should not exceed 256 characters.

OE2041 allows users to query the current value of internal parameters through commands. A query is formed by appending a question mark "?" to the command mnemonic and omitting the desired parameter(s) from the command. Values returned by the OE2041 are sent as a string of ASCII characters terminated by a corresponding terminator. If multiply queries are sent on one command line (separated by semicolons), the answers will be returned individually, each with a terminator.

Examples of Command Formats

FMOD1<cr>	Set reference source to internal
FREQ10E3<cr>	Set the internal reference frequency to 10kHz
OUTP?1<cr>	Query output value of X of fundamental wave

5.2 Detailed Command List

The parameters in each command sequence specify the command. Multiple parameters are separated by commas. Parameters shown in {} are optional. Commands that may be queries have a question mark in parentheses (?) after the mnemonic. Do not send () or {} as part of the command.

The variables are defined as follows.

i, j, k, l, m, n, o, p, q, r, s, t, u	integers
---------------------------------------	----------

x	real numbers
f	frequency

Note that all numeric variables can be expressed in integer, floating point or exponential formats (i.e., the number five can be 5, 5.0, or .5E1). Strings are sent as a sequence of ASCII characters.

5.2.1 Input and Filter Commands (Reference and Phase Commands)

ISRC (?) {i} The ISRC command sets or queries the input configuration.
The parameter i selects A (single voltage input mode) (i=0), <A-B> (differential voltage input mode) (i=1).

INHZ (?) {i} The INHZ command sets or queries the input impedance.
The parameter i selects 50 Ω (i=0), 10 M Ω (i=1).

IGND (?) {i} The IGND command sets or queries the input shield grounding.
The parameter i selects <Float> mode (i=0) when the input ground is connected to the instrument ground with 1 k Ω resistor or <Ground> mode (i=1) when the input ground is connected to the instrument ground with 0 Ω resistor.

ICPL (?) {i} The ICPL command sets and queries the input coupling.
The parameter i selects <AC> (i=0) or <DC> (i=1).

5.2.2 Sensitivity and Time Constants Commands (Equation Commands)

SENS(?) {i} The SENS command sets or queries the sensitivity. The parameter i is used to select a different range.

i sensitivity	i sensitivity
0: 1 nV/fA	14: 50 μ V/pA
1: 2 nV/fA	15: 100 μ V/pA
2: 5 nV/fA	16: 200 μ V/pA
3: 10 nV/fA	17: 500 μ V/pA
4: 20 nV/fA	18: 1 mV/nA
5: 50 nV/fA	19: 2 mV/nA
6: 100 nV/fA	20: 5 mV/nA
7: 200 nV/fA	21: 10 mV/nA
8: 500 nV/fA	22: 20 mV/nA
9: 1 μ V/pA	23: 50 mV/nA
10: 2 μ V/pA	24: 100 mV/nA
11: 5 μ V/pA	25: 200 mV/nA
12: 10 μ V/pA	26: 500 mV/nA
13: 20 μ V/pA	27: 1 V/ μ A

IRNG (?) {i} The IRNG command is used to set or query the Input Range of the system. The parameter i is used to select a Input Range value below.

i	Input Range
0	1V
1	200 mV
2	50 mV
3	10 mV
4	2 mV
5	400 uV

OFLT(?)*{i}* The OFLT command sets or queries the time constant of filters. The parameter *i* selects a time constant below.

i/time constant	i/time constant
0: 30 ns	19: 16 ms
1: 60 ns	20: 32 ms
2: 125 ns	21: 65 ms
3: 250 ns	22: 125 ms
4: 500 ns	23: 250 ms
5: 1 us	24: 500 ms
6: 2 us	25: 1 s
7: 4 us	26: 2 s
8: 8 us	27: 4 s
9: 16 us	28: 8 s
10: 32 us	29: 17 s
11: 64 us	30: 35 s
12: 125 us	31: 70 s
13: 250 us	32: 140s
14: 500 us	33: 275 s
15: 1 ms	34: 550 s
16: 2 ms	35: 1100 s
17: 4 ms	36: 2200 s

OFSL(?)*{i}* The OFSL command sets or queries the low pass filter slope. The parameter *i* selects a slope below.

i	Filter dB/oct
0	6 dB/oct
1	12 dB/oct
2	18 dB/oct
3	24 dB/oct
4	30 dB/oct
5	36 dB/oct
6	42 dB/oct
7	48 dB/oct

SYNC(?)*{i}* The SYNC command sets or queries the status of synchronous filter. The parameter *i* selects Off (*i*=0) or On (*i*=1). The synchronous filtering should be turned on only when the reference frequency is less than 200 Hz.

5.2.3 Reference and Phase Commands

PHAS(?) <i>{x}</i>	<p>The PHAS command sets or queries the reference phase shift. The parameter <i>x</i> refers to the phase (real number, unit: °). The PHAS <i>x</i> command will set the current phase shift to x°.</p> <p>The value of <i>x</i> is rounded to 0.01°. The phase can be programmed from -180° to $+180^\circ$. For example, send command "PHAS -179.0" and the phase shift will be set to -179°. The PHAS? command queries the phase shift.</p>
FMOD(?) <i>{i}</i>	<p>The FMOD command sets or queries the reference source. The parameter <i>i</i> selects external reference (<i>i</i>=0), internal reference (<i>i</i>=1), internal sweep reference (<i>i</i>=2) or self reference (<i>i</i>=3).</p>
FREQ(?) <i>{f}</i>	<p>The FREQ command sets or queries the frequency of internal reference signal. The frequency value can be set in the range of 1 mHz-60 MHz, with a minimum resolution of 1 mHz. The FREQ? command will return the current reference frequency (internal or external).</p>
RSLP(?) <i>{i}</i>	<p>The RSLP command sets or queries the trigger way of reference signal when in external reference mode.</p> <p>The parameter <i>i</i> selects <TTL> rising edge (<i>i</i>=0) or <Sine> zero crossing (<i>i</i>=1). When the frequency is less than 1 Hz, the <TTL> reference must be used.</p>
SWPT(?) <i>{i}</i>	<p>The SWPT command sets or queries the mode of internal frequency sweep. The parameter <i>i</i> selects <Linear> (<i>i</i>=0) or <Log> (<i>i</i>=1).</p>
SLLM(?) <i>{f}</i>	<p>The SLLM command sets or queries the <Start> frequency in internal frequency sweep mode. The SLLM? command will return the start frequency. The range of <i>f</i> is 1 mHz-60 MHz and the minimum resolution is 1mHz.</p>
SULM(?) <i>{f}</i>	<p>The SULM command sets or queries the <Stop> cutoff frequency in internal frequency sweep mode. The SULM? command will return the cutoff frequency. The range of <i>f</i> is 1 mHz-60 MHz and the minimum resolution is 1mHz.</p>
SSLL(?) <i>{f}</i>	<p>The SSLL command sets or queries the step frequency in <Linear> internal frequency sweep mode. The SSLL? command will return the step frequency. The range of <i>f</i> is 1 mHz-60MHz and the minimum resolution is 1mHz.</p>
SSLG(?) <i>{x}</i>	<p>The SSLG command sets or queries the percentage in <Log> internal sweep mode. The SSLG? command will return the percentage in <Log> frequency sweep mode. The range of <i>x</i> is 0.001-100 and the minimum resolution is 0.001. $x=50$ means that the percentage is 50%.</p>

- STLM(?)i}** The STLM command sets or queries the step time in internal frequency sweep mode. The STLM? command will return the step time of internal sweep mode. The range of i is 1ms-100,000ms and the minimum resolution is 1ms.
- SWRM(?)i}** The SWRM command sets or queries the running mode in internal frequency sweep mode. The parameter i selects <STOP> (i=0) , <Single> (i=1) or <Loop> (i=2).
- DMOD(?)i{j}** The DMOD command sets or queries the mode of 3 demodulators. When sending this instruction i must be set. The parameter i selects demodulator 1(i=0), demodulator 2(i=1), or demodulator 3(i=2).The parameter j selects harmonic mode(j=0), arbitrary frequency demodulation mode(j=1), or formula combination frequency demodulation mode(j=2) of the demodulator. The command DMOD?i returns the demodulation mode of the currently queried demodulator.
- HARM(?)i{j}** The HARM command sets or queries harmonic order. When sending this instruction i must be set, corresponding to the 3 demodulators of OE2041. The parameter i selects harmonic of demodulator 1(i=0), harmonic of demodulator 2 (i=1), or harmonic of demodulator 3(i=2). The parameter j is an integer from 1 to 32767, indicating the order of harmonic. The HARM i,j command will set OE2041 to detect at the jth harmonic of reference frequency. The value of j is limited by $j \cdot f \leq 60\text{MHz}$. If the value of j requires a detection frequency larger than 60MHz, then j will be set to the maximum value that meets this condition.
- DARB (?) i {, f}** The DARB command sets or queries the reference frequency of the modulator in arbitrary frequency mode. When sending this instruction i must be set, corresponding to the 3 demodulators of OE2041. The parameter i selects frequency of demodulator 1(i=0), frequency of demodulator 2 (i=1), or frequency of demodulator 3(i=2). The range of f is 1 mHz-60MHz and the minimum resolution is 1mHz.
- DEQU(?)i{j,k,l,m}** The DEQU command sets or queries the formula parameters of the modulator in formula combination mode. When sending this instruction i must be set, corresponding to the 3 demodulators of OE2041. The parameter i selects frequency of demodulator 1(i=0), frequency of demodulator 2 (i=1), or frequency of demodulator 3(i=2). The parameters j,k,l,m correspond to the four parameters A,F1,B,F2 of the formula $E=A \cdot F1+B \cdot F2$. j and l can be set to integers in the range -32767 to 32767, and k and m can be set in the range 1mHz-60MHz with a minimum resolution of 1 mHz.

5.2.4 Sine Wave Output Commands

SADD (?) {i}	The SADD command sets or queries the enable status of ADD-IN interface and add function. The parameter i selects interface disabled (i=0), or interface enabled (i=1). The SADD? Command will return the status of ADD-IN interface.
SWVT(?) {i}	The SWVT command sets or queries the output type of <Sine Output>. The parameter i selects turning off Sineout output (i=0), fixed amplitude output (i=1), linear amplitude sweeping output (i=2) or proportional amplitude sweeping output (i=3).
SLVL(?) {x}	The SLVL command sets or queries the amplitude of the output synchronous sine wave. The parameter x determines the amplitude of voltage (real number, unit: V). The range of x is $1\mu\text{Vrms} \leq x \leq 1\text{Vrms}$ and the minimum resolution of x is 1 μVrms .
SVLL(?) {x}	The SVLL command sets or queries <Start> amplitude in <Sine Output> sweep mode. The SVLL? command will return the start amplitude of sweeping amplitude. The range of x is $0.001\text{Vrms} \leq x \leq 5.000\text{Vrms}$ and the minimum resolution is 0.001Vrms.
SVUL(?) {x}	The SVUL command sets or queries <Stop> cutoff amplitude in <Sine Output> sweep mode. The SVUL? command will return the cutoff amplitude of sweeping amplitude. The range of x is $1\mu\text{Vrms} \leq x \leq 1\text{Vrms}$ and the minimum resolution is 1 μVrms .
SVSL(?) {x}	The SVSL command sets or queries <Step> amplitude in <Linear> <Sine Output> sweep mode. The SVSL? command will return the step amplitude of linear sweeping amplitude mode. The range of x is $0.000 \text{Vrms} \leq x \leq 5.000\text{Vrms}$ and the minimum resolution is 0.001Vrms.
SVSG(?) {x}	The SVSG command sets or queries the percentage in <Log> <Sine Output> sweep mode. The SVSG? command will return the percentage in <Log> sweep amplitude mode. The range of x is 0-100 and the minimum resolution is 0.001. x=50 means that the percentage is 50%.
SVTM(?) {x}	The SVTM command sets or queries step <Time> in <Sine Output> sweep mode. The SVTM? command will return the step <Time> of logarithm amplitude sweeping. The range of x is 1ms-100,000ms and the minimum resolution is 1ms.
SVRM(?) {i}	The SVRM command sets and queries the executing mode in <Sine Output> sweep mode. The parameter i selects <Stop> (i=0), <Single> (i=1) or <Loop> (i=2).

5.2.5 Channel Output Commands

COUT(?)i{j} The COUT command sets or queries the CHOUT/AUXOUT output channels of rear panel. The parameter i must be set when sending this command. The parameter i selects CH1 (i=0), CH2 (i=1), CH3 (i=2) or CH4 (i=3). The parameter j is used to select the source of output. More details are as follow.

i	Source of Output
0	AUXOUT
1	X
2	Y
3	R
4	θ
5	XD1
6	YD1
7	RD1
8	θ D1
9	XD2
10	YD2
11	RD2
12	θ D2
13	XD3
14	YD3
15	RD3
16	θ D3
17	X-Noise
18	Y-Noise
19	Frequency
20	AUX-IN1
21	AUX-IN2
22	AUX-IN3
23	AUX-IN4

CAUX (?)i{x} The CAUX command sets or queries the AUXOUT output values. The parameter i is used to select a corresponding CH channel. The parameter i selects CHOUT1 (i=0), CHOUT2 (i=1), CHOUT3 (i=2) or CHOUT4 (i=3). The parameter x is used to set the voltage of DAC. The voltage range is $-10.000V \leq X \leq 10.000V$. For example, send command "OAUx 2,5.00" and then the output voltage of <CHOUT3> in AUXOUT mode is set to 5.00V.

COFP (?) i {, x} The COFP command sets or queries the output bias value of CHOUT channel. The parameter i is used to select a corresponding CH channel. The parameter i selects CHOUT1 (i=0), CHOUT2 (i=1), CHOUT3 (i=2) or CHOUT4 (i=3). The

parameter x is used to set the bias value in the range of $(-100.00 \leq x \leq 100.00)\%$ with a minimum resolution of 0.01.

- CEXP(?)i{j} The CEXP i command sets or queries the output expands of CHOUT channel. The parameter i is used to select a corresponding CH channel. The parameter i selects CHOUT1 ($i=0$), CHOUT2 ($i=1$), CHOUT3 ($i=2$) or CHOUT4 ($i=3$). The parameter j is used to set the output expands in the range of $(1 \leq x \leq 256)$ integers.
- CSPE(?)i The CPED command sets or queries the executing mode of <Channel Output>. The parameter i selects <Slow> ($i=0$) or <Fast> ($i=1$).

5.2.6 Auto Set Commands

- ARNG The ARNG command performs the Auto Range function. It is the same as pressing the [Auto Range] key.
- AGAN The AGAN command performs the Auto Gain function. It is the same as pressing the [Auto Gain] key. Auto Gain may fail if the time constant is long.
- APHS The APHS command performs the Auto Phase function. It is the same as pressing the [Auto Phase] key.
The outputs will take some time to reach their new values. Do not send a new APHS command before the auto set finished. If the phase is unstable, then APHS will do nothing.
Use PHAS? Command to query the new value of the phase shift and see if APHS changed the phase shift.

5.2.7 Save and Recall Setup Commands

- SSET i The SSET i command saves the current setup of OE2041 in setting buffer i ($1 \leq i \leq 4$). The parameter i selects S1 ($i=1$), S2 ($i=2$), S3 ($i=3$) or S4 ($i=4$). The setting buffers are retained when the power is off.
- RSET i The RSET i command recalls the saved setup information from buffer i ($0 \leq i \leq 4$). After executed the RSET i command, the internal parameters will be set as corresponding parameter in the setting buffer i . The parameter i selects S1 ($i=1$), S2 ($i=2$), S3 ($i=3$), S4 ($i=4$) or Default ($i=0$).

5.2.8 Reset and IDN Commands (Data Store Commands)

- *RST The RST command is used to reset OE2041 to its default configurations. All internal status and parameters are set to their default conditions and values.

Data stored in the buffers will be lost. The * sign is to complete the 4-bit command character.

*IDN? The IDN? query returns the OE2041’s device identification string. This string is in the format “SSL LIA-OE2041, SNXXXXXX, VerXXX”. In this example, the model name is OE2041; the serial number is SN00001; the firmware version is Ver1.00. The * sign is to complete the 4-bit command character.

5.2.9 Data and Status Read Commands

SNAP?i,j,{k,l,m,n,o,p,q,r,s,t,u} The SNAP?i,j command records the values of no more than 13 parameters at a single instant.

For example, SNAP? is a way to query values of <X>, <Y>, <R>, <θ> and <F> which are taken at the same time. This is important when the time constant is very short. Using the OUTP? commands will result in time delays, which may be greater than the time constant, between reading two different parameters.

The SNAP?i,j command requires at least two parameters and at most thirteen parameters. The parameters i, j, k, l, m, n, o, p, q, r, s, t, u select the parameters below.

i,j,k,l,m,n,o,p,q,r,s,t,u	Parameter
0	X
1	Y
2	R
3	θ
4	Frequency
5	XD1
6	YD1
7	RD1
8	θD1
9	XD2
10	YD2
11	RD2
12	θD2
13	XD3
14	YD3
15	RD3
16	θD3
17	X-Noise
18	Y-Noise
19	AUX-IN1
20	AUX-IN2
21	AUX-IN3
22	AUX-IN4

The requested values are returned in a single string with the values separated by commas and in the order in which they are requested. For example, the SNAP?0,1,4,3 will return the values of <X>, <Y>, <Frequency> and < θ >. These values will be returned in a single string such as "0.951359,0.0253297,1000.00,1.234". The first value is <X>, the second is <Y>, the third is <Frequency> and the fourth is < θ >.

The advantage of this command over the OUTF command is that multiple data can be acquired at the same time, all of which are at the same moment and there is no delay.

OUTP? i

The OUTP? i command is used to read a single parameter value. The parameter i selects the parameters as the following.

i	Parameter
0	X
1	Y
2	R
3	θ
4	Frequency
5	XD1
6	YD1
7	RD1
8	θ D1
9	XD2
10	YD2
11	RD2
12	θ D2
13	XD3
14	YD3
15	RD3
16	θ D3
17	X-Noise
18	Y-Noise
19	AUX-IN1
20	AUX-IN2
21	AUX-IN3
22	AUX-IN4

Values are returned as ASCII floating point numbers with units of Volts, degrees or Hz, while units will not be output. This command is a query only command.

OAX? i

The OAX? command queries input voltage values of the AUX-IN interfaces on the rear panel. The parameter i must be set when sending this command. The

parameter *i* selects AUX-IN1 (*i*=0), AUX-IN2 (*i*=1), AUX-IN3 (*i*=2) or AUX-IN4 (*i*=3). The query returns results in Volts (V), but the units are not output.

INOV? The INOV? command queries the status of Input Overload. The query returns 0 or 1, where 0 means there is no overload in the front stage; 1 means there is overload in the front stage, and the input signal should be reduced to protect OE2041 from damage.

GNOV? The GNOV? command queries the status of Gain Overload. The query returns 0 or 1, where 0 means the ADC is not overloaded, and 1 means the ADC is overloaded, and the input signal and input gain multiplier should be reduced to protect OE2041 from damage.

***PLL?** The *PLL? command queries the status of the phase-locked loop. The query returns 0 or 1, where 0 means the PLL is not locked or is in internal reference mode, and 1 means the PLL is locked.

5.2.10 Global Data & Configuration Read Command

RALL? The RALL? command is specific to the USB2.0 and Ethernet interfaces and is not available for the RS232 interface.

The RALL? command is used to read all measurement data and current configuration information of OE2041. The length of the returned data is 8192Bytes, with no comma separating the data, and the data combination is allocated according to the fixed space. The data returned by the RALL? command is updated every 50ms, returning the measurement data, and the data sampling interval is 1ms, that is, each time returning the measurement data of previous 50ms. For example, the first 400 Bytes data for 50 X-value data, each X-value is a 64-bit floating point number, occupying 8 Bytes, 50 X-values in chronological order; then to the Y-value The first 6000 Bytes is to return measurement data, and then the last 2192Bytes is the current configuration information, each configuration information is not like the data will return 50 values, but only return parameters 1 time.

RALL? The return data format is as follows.

Classification	Returned data	Data Location
Measurement Data	50 X values (64-bit floating-point)	0~399
	50 Y values (64-bit floating-point)	400~799
	50 frequency values (64-bit floating-point)	800~1199
	50 X-Noise values (64-bit floating-point)	1200~1599
	50 Y-Noise values (64-bit floating-point)	1600~1999
	50 XD1 values (64-bit floating-point)	2000~2399
	50 YD1 values (64-bit floating-point)	2400~2799

	50 XD2 values (64-bit floating-point)	2800~3199
	50 YD2 values (64-bit floating-point)	3200~3599
	50 XD3 values (64-bit floating-point)	3600~3999
	50 YD3 values (64-bit floating-point)	4000~4399
	50 AUX-IN1 values (64-bit floating-point)	4400~4799
	50 AUX-IN2 values (64-bit floating-point)	4800~5199
	50 AUX-IN3 values (64-bit floating-point)	5200~5599
	50 AUX-IN4 values (64-bit floating-point)	5600~5999
Input Filters Configuration Parameters	<Source> configurations (8-bit integer)	6000
	<Impedance> configurations (8-bit integer)	6001
	<Grounding> configurations (8-bit integer)	6002
	<Coupling> configurations (8-bit integer)	6003
Gain TC Configuration Parameters	<Sensitivity> configurations (8-bit integer)	6008
	<Gain> configurations (8-bit integer)	6009
	<Time Constant> configurations (8-bit integer)	6010
	<Filter dB/oct> configurations (8-bit integer)	6011
	<Sync Filter> configurations (8-bit integer)	6012
Ref Phase Configuration Parameters	<Ref.Source> configurations (8-bit integer)	6013
	<Ref.slope> configurations (8-bit integer)	6014
	<Ref.Phase> configurations (32-bit floating-point)	6015~6018
	<Ref.Frequency> configurations (64-bit floating-point)	6019~6026
	<Sweep Type> configurations (8-bit integer)	6027
	<Sweep Run> configurations (8-bit integer)	6028
	<SweepStartFreq> configurations (64-bit floating-point)	6029~6036
	<SweepStopFreq> configurations (64-bit floating-point)	6037~6044
	<SweepStepFreq> configurations (64-bit floating-point)	6045~6052
	<SweepStepPerc> configurations (32-bit floating-point)	6053~6056
Demod Configuration Parameters	<Sweep Time> configurations (32-bit integer)	6057~6060
	<Demod D1 Type> configurations (8-bit integer)	6081
	<Demod D2 Type> configurations (8-bit integer)	6082
	<Demod D3 Type> configurations (8-bit integer)	6083
	< D1 Harmonic Set> configurations (16-bit integer)	6084~6085
	< D2 Harmonic Set> configurations (16-bit integer)	6086~6087
	< D3 Harmonic Set> configurations (16-bit integer)	6088~6089
	<D1 Arb Freq Set> configurations (64-bit floating-point)	6090~6097
	<D2 Arb Freq Set > configurations (64-bit floating-	6098~6105
	<D3 Arb Freq Set > configurations (64-bit floating-	6106~6113
	<D1 Equation A> configurations (16-bit integer)	6114~6115
	<D2 Equation A> configurations (16-bit integer)	6116~6117
	<D3 Equation A> configurations (16-bit integer)	6118~6119
	<D1 Equation B> configurations (16-bit integer)	6120~6121
	<D2 Equation B> configurations (16-bit integer)	6122~6123
	<D3 Equation B> configurations (16-bit integer)	6124~6125
	<D1 Equation F1> configurations (64-bit floating-point)	6126~6133
	<D2 Equation F1> configurations (64-bit floating-point)	6134~6141
	<D3 Equation F1> configurations (64-bit floating-point)	6142~6149
	<D1 Equation F2> configurations (64-bit floating-point)	6150~6157
<D2 Equation F2> configurations (64-bit floating-point)	6158~6165	

	<D3 Equation F2> configurations (64-bit floating-point)	6166~6173
Sineout Configuration Parameters	<Add Mode> configurations (8-bit integer)	6214
	<Output Mode> configurations (8-bit integer)	6215
	<Sineout Voltage> configurations (32-bit floating-point)	6216~6219
	<SweepStartVolt> configurations (32-bit floating-point)	6220~6223
	<SweepStopVolt> configurations (32-bit floating-point)	6224~6227
	<SweepStepVolt> configurations (32-bit floating-point)	6228~6231
	<SweepStepPrec> configurations (32-bit floating-point)	6232~6235
	<Sweep Time> configurations (32-bit integer)	6236~6239
	<Sineout Sweep Run> configurations (8-bit integer)	6240
CHOUT Configuration Parameters	<CH1 Output Source> configurations (8-bit integer)	6261
	<CH2 Output Source> configurations (8-bit integer)	6262
	<CH3 Output Source> configurations (8-bit integer)	6263
	<CH4 Output Source> configurations (8-bit integer)	6264
	<CH1 AUXOUT> configurations (32-bit floating-point)	6265~6268
	<CH2 AUXOUT> configurations (32-bit floating-point)	6269~6272
	<CH3 AUXOUT> configurations (32-bit floating-point)	6273~6276
	<CH4 AUXOUT> configurations (32-bit floating-point)	6277~6280
	<CH1 Offset> configurations (32-bit floating-point)	6281~6284
	<CH2 Offset> configurations (32-bit floating-point)	6285~6288
	<CH3 Offset> configurations (32-bit floating-point)	6289~6292
	<CH4 Offset> configurations (32-bit floating-point)	6293~6296
	<CH1 Expand> configurations (16-bit integer)	6297~6298
	<CH2 Expand> configurations (16-bit integer)	6299~6300
	<CH3 Expand> configurations (16-bit integer)	6301~6302
	<CH4 Expand> configurations (16-bit integer)	6303~6304
	<CH Output Speed> configurations (8-bit integer)	6305
Status Parameters	Input Overload status (8-bit integer)	6322
	Gain Overload status (8-bit integer)	6323
	PLL Locked status (8-bit integer)	6324
IDN Serial Number	IDN serial number return value (40Bytes)	8146~8185

6. COMPUTER OPERATION

6.1 Install Software

The required software is provided with the CD disk as below: Fig 48

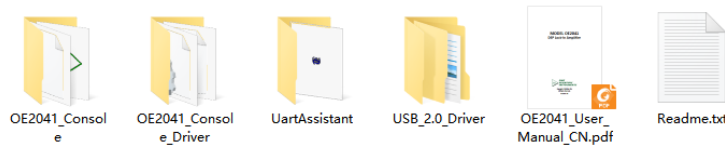

Fig.48 Software files in the CD disk.

1. Install the USB2.0 Driver

Make sure the USB 2.0 driver loads properly. For a Windows 10 user, this step can be skipped. For a Windows 7/8/8.1 user, the USB 2.0 driver should be installed first by opening the fourth folder in Fig.48, "USB_2.0_Driver", as shown in Fig.49.

Name	Date modified	Type
CDC	2021-04-16 15:43	File folder
HID	2021-04-16 15:43	File folder
PHDC	2021-04-16 15:43	File folder
USBDev_API	2021-04-16 15:43	File folder
Vendor	2021-04-16 15:43	File folder

Fig.49 "USB_2.0_Driver" folder

Make sure the OE2041 rear panel USB 2.0 port is connected to the PC USB port, then start the OE2041 and change the <Remote Mode> mode to <USB 2.0>.

Open the device manager of your PC (Open method: "My Computer" -> Right click -> Properties -> Device Manager -> Ports (COM and LPT)), you can see the device manager as in **Error! The source of the citation was not found.** Fig.50 shows that the unknown device "CDC Device" is the USB interface of OE2041. Right click on the "CDC Device" and select "Update Driver" in the pop-up menu, which will bring up the interface shown in Fig.51 (left). Click the second item "Browse Computer for Driver Software" in Fig.50 (left), and then click "Select from your computer's device driver list" in the following page in Fig.50 (right).

Then the next screen as shown in Fig.52 (left), select "Port (COM and LPT)", click Next, Fig.51 (right) screen appears, select "Install from disk". After that, the window in Fig.53 (left) will pop up, click "Browse" to select the path of "USB_2.0_Driver\CDC\INF", and then click "OK". The system will recognize the driver information as shown in Fig.52 (right), click "Next", click "Yes" in the warning window that pops up (Fig.53 left), and the window shown in Fig.54 (right) will also pop up, click the following option "Always install this driver software".

The final installation process is as shown in Fig.55, wait for some time to complete the driver installation.

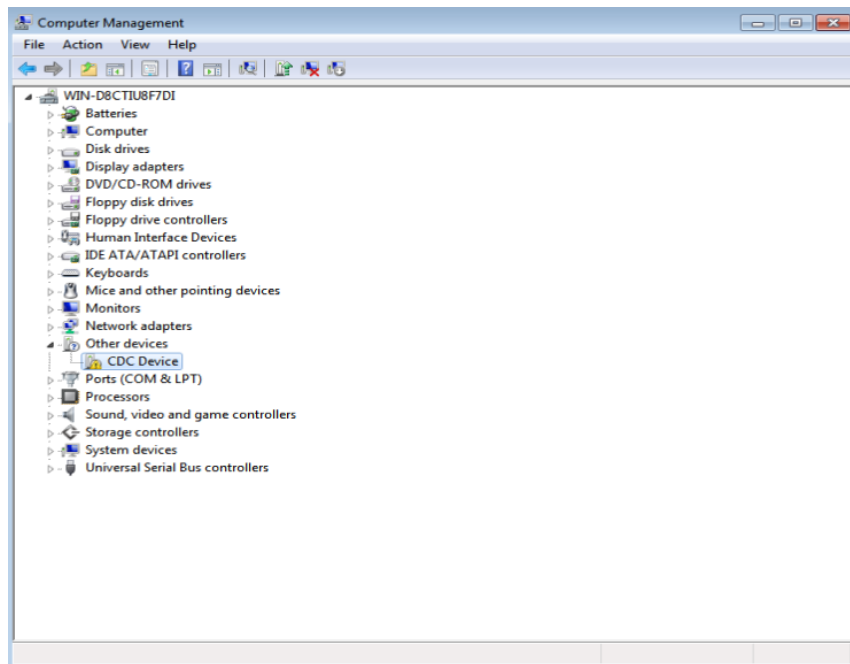

Fig.50 Device Manager Interface

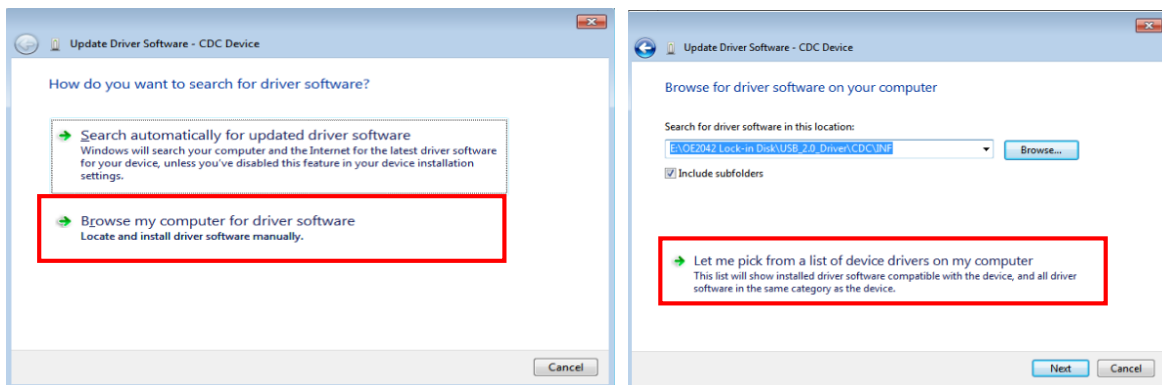

Fig.51 Update Driver Process Part.1

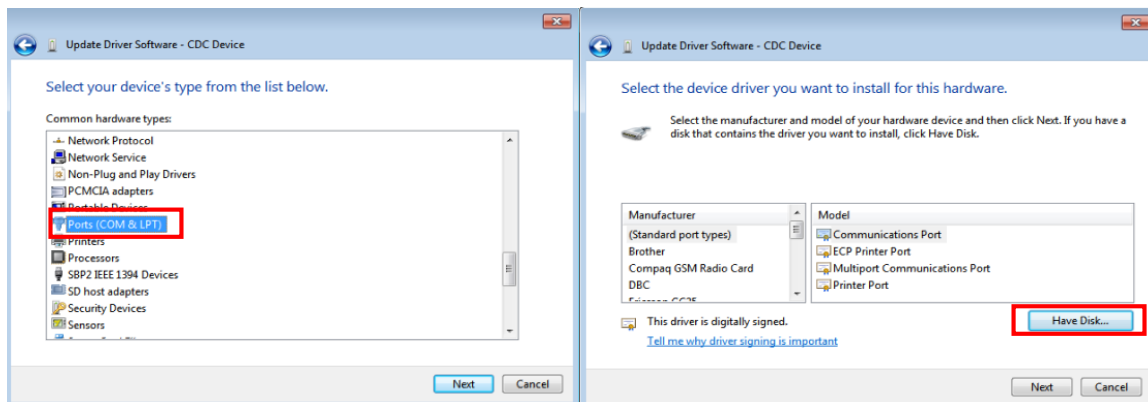

Fig.52 Update Driver Process Part.2

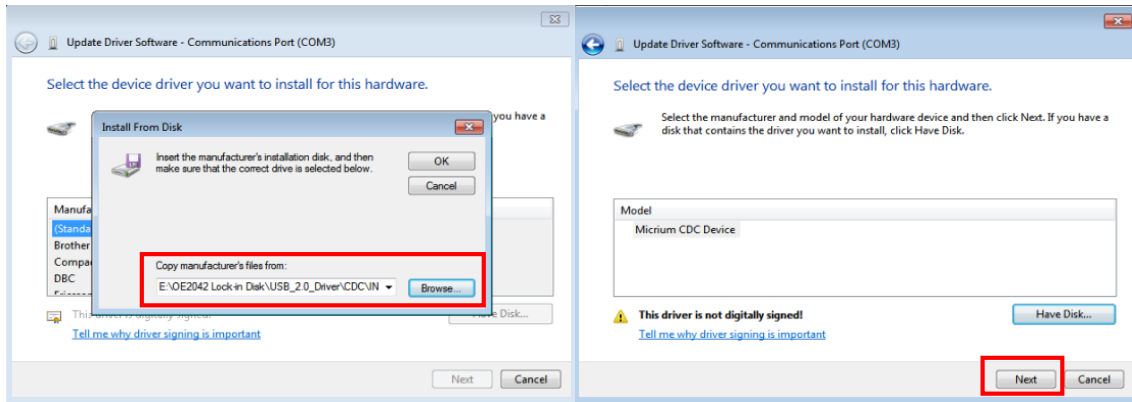

Fig.53 Update Driver Process Part.3

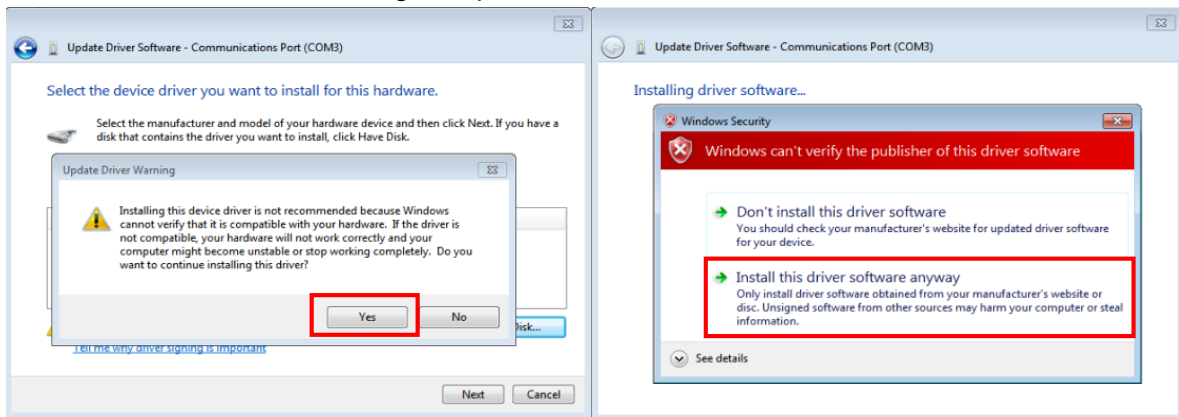

Fig.54 Update Driver Process Part.4

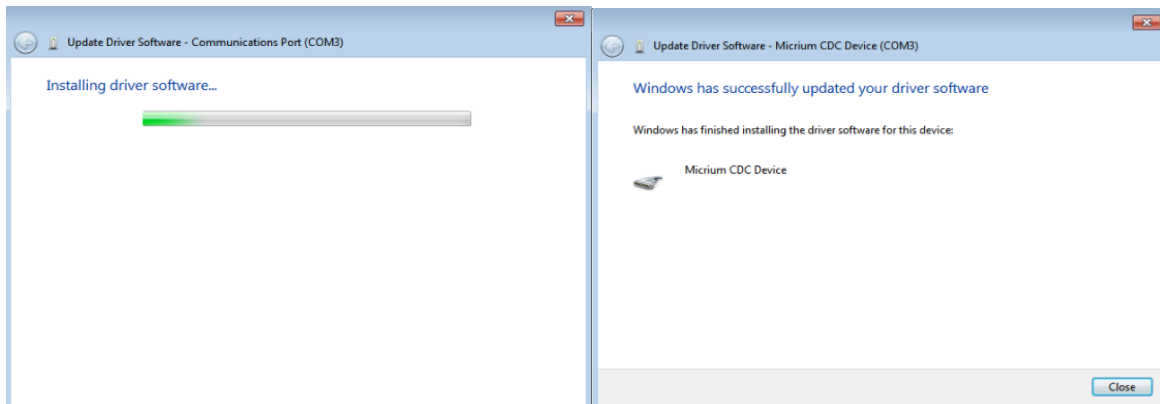

Fig.55 Update Driver Process Part.5

Now, use the USB cable to connect the PC and the lock-in amplifier, then the connection is automatically recognized as successful, and the recognized COM port can be seen in the device manager. The USB2.0 driver is a virtual serial driver, which is used in the same way as the serial port after the successful connection, and there is no need to match the baud rate.

2. Install OE2041 Software Driver

If the PC does not have NI LabView 2017 or higher versions installed locally, the user need to

install the driver in the second folder in Fig.48 and open "OE2041_Console_Driver", as shown in Fig.56.

Name	Date modified	Type
bin	2021-04-16 15:43	File folder
license	2021-04-16 15:43	File folder
supportfiles	2021-04-16 15:43	File folder
nidist.id	2020-05-11 18:27	ID File
setup	2017-03-15 19:10	Application
setup	2020-05-11 18:27	Configuration sett...

Fig.56 "OE2041 software driver" Folder

Double-click to open the "setup.exe" installation file in the red box in the figure above to start installing the OE2041 PC software environment driver, generally according to the default options to install on it.

Note that after successful installation, restart the computer to complete the configuration of the software environment.

3. Install OE2041_Console_EN.

If the previous installation steps are all completed, the user can open the first folder "OE2041_Console" in Fig.48. This file contains both English and Chinese versions of the application software, which can run normally under Windows 7/8/8.1/10 systems.

Open the first folder in Fig.48, "OE2041", with the following files.

Name	Date modified	Type	Size
OE2042_Console_EN.aliases	2021-04-16 9:57	ALIASSES File	1 KB
SSI OE2042_Console_EN	2021-04-16 9:57	Application	1,196 KB
OE2042_Console_EN	2021-04-16 9:57	Configuration sett...	1 KB

Fig.57 "OE2041" Folder

Double click to open the "OE2041_Console_EN.exe" file in the red box in Fig.57. If the previous installation is correct, the following software window will pop up and you can start the lock-in amplifier configuration on your PC. After opening, the following Fig.58 shows.

Note that if the PC has NI LabView 2017 or higher version installed, you only need to install the serial driver (the first step) and then proceed directly to the third step to use the lock-in amplifier configuration software to set the parameters.

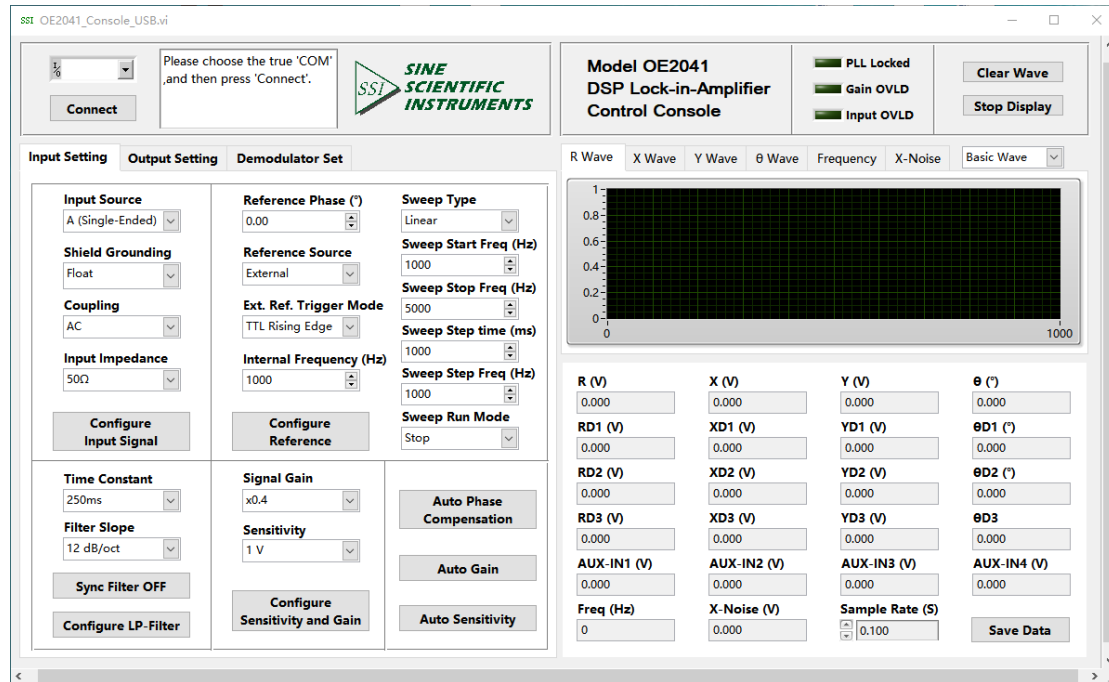

Fig.58 OE2041 Software Interface

6.2 How to Use the Software

Fig.58 shown above shows the interface of the PC configuration software for the current version of the lock-in amplifier OE2041 (hereinafter referred to as OE2041).

6.2.1 Begin to Run

Before the program runs as shown in Fig.59 (left), the upper left part of Fig.58, the message "Please choose the true 'COM', and then press 'Connect'." is displayed. ". If the program has been successfully connected, the upper left corner of the program will change to the part shown in Fig.59 (right), and the button will change to "Connected", and the current device information will be displayed. At this point, if you click the button "Connected" again, you can stop the current software operation.

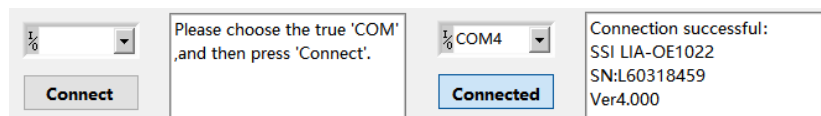

Fig.59 (left) Program begins (right) Program runs.

6.2.2 Connection

To use the software to properly configure OE2041, the user first need to complete the proper connection between the PC and the OE2041. Fig.60 shows the part of the software interface that displays the current connection status.

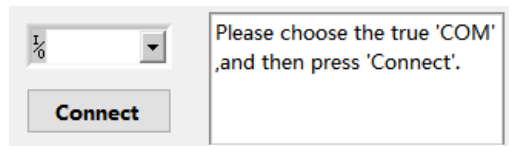

Fig.60 Initial Status

As shown in Fig.60, first find the COM number information corresponding to OE2041 in the device manager, select the COM port in the drop-down window in the upper left corner, then click on the connection option "Connect" on the left, if the PC and OE2041 are successfully connected, the window below will show the version number information of the OE2041, as shown in Fig.61.

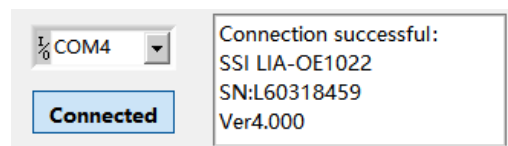

Fig.61 Connection Succeeds

Wait for a few seconds. If the message window on the right shows "Connection failed, please retry." like Fig.62, it means that the connection between PC and OE2041 fails.



Fig.62 Connection fails.

After reconfirming that the device is properly connected and the correct COM port is selected, click the "Connected" button to switch the software back to the initial state (Fig.60), and click "Connect" again to try to connect until the connection is successful.

When the connection is successful, as shown in Fig.63, the contents of the window in the red box will be cleared and the values will start to be displayed again, with the default window displaying the R value and the X, Y, θ , frequency or noise values are optional to be displayed at the top of the red box. At the same time, the software interface will be updated to display the parameters of the current configuration of OE2041.

Note: Please connect the PC to OE2041 with the USB cable before opening the software. If the software is opened before connecting the USB cable, there is a high probability that the connection will not be successful.

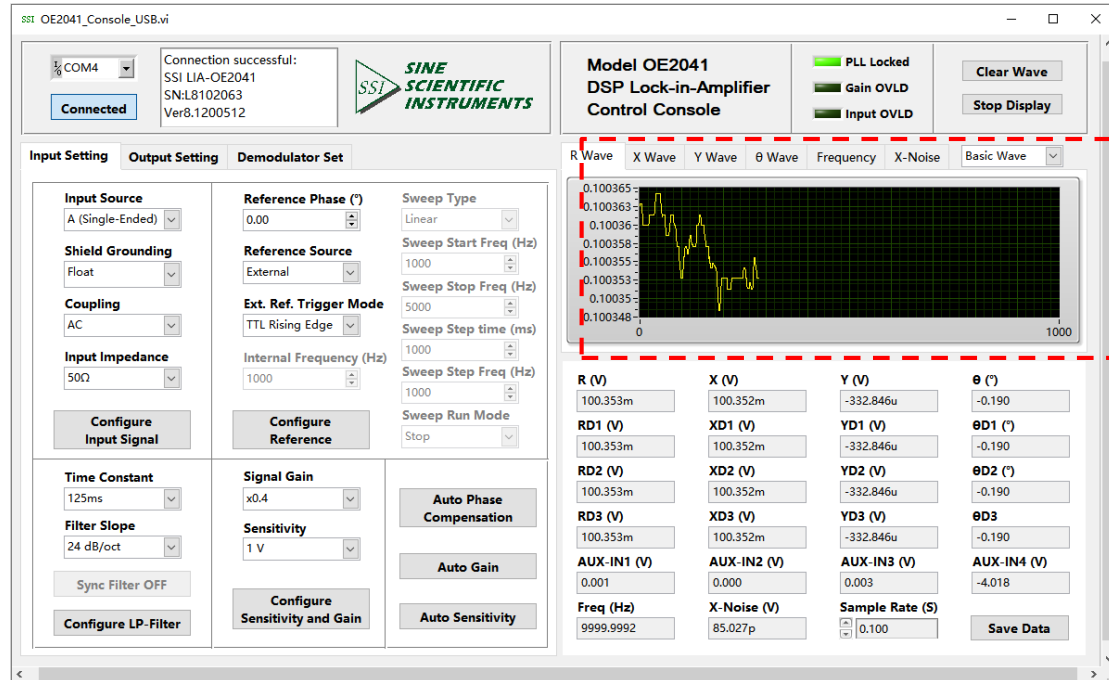

Fig.63 OE2041 Software Connection Succeeds

6.2.3 Input Configuration

The program configuration area of input signal is as shown in the red box in Fig.63. The details of the configuration are listed on Table 5.

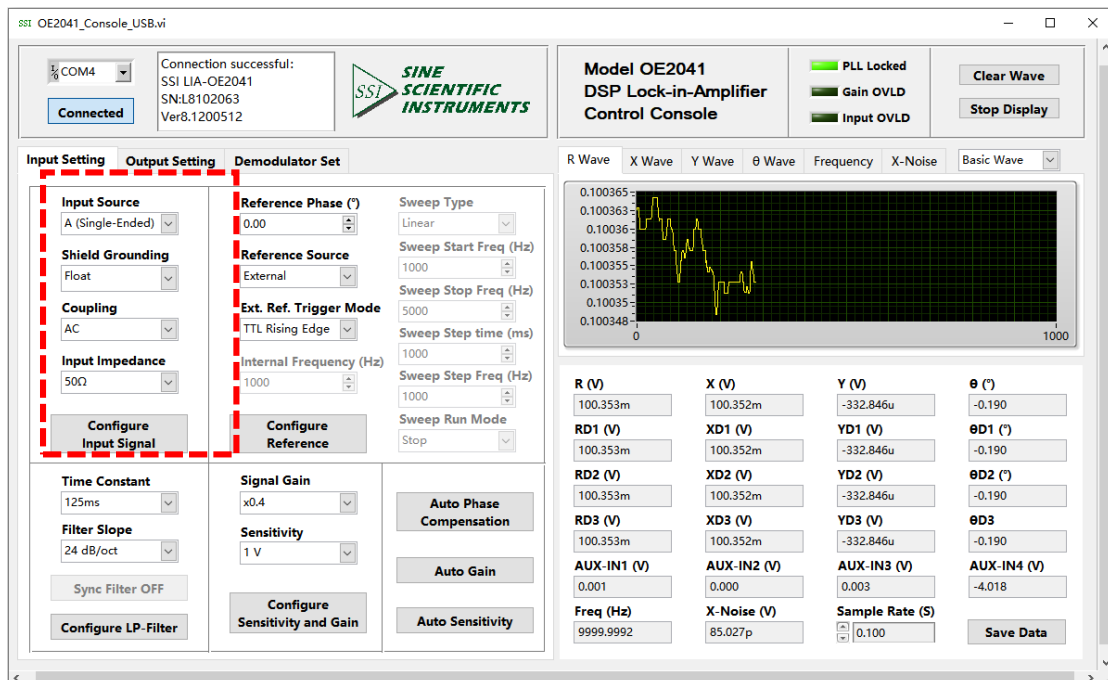

Fig.64 The Configuration area of Input Signal

Input Source	Single-Ended Voltage
	Differential Voltage
Input Shield Grounding	Float (The input connector ground and the instrument ground are isolated by a 1 k Ω resistor.)
	Ground (The input connector ground and the instrument ground are isolated by a 0 Ω resistor.)
Input Coupling	AC (AC coupling)
	DC (DC coupling)
Input Impedance	50 Ω (The impedance is 50 Ω)
	10 M Ω (The impedance is 10 M Ω)

Note that:

1. After selecting the desired settings, you need to click “[Configure Input Signal](#)” to complete the configuration of the input signal.

All settings can be changed at the same time, just click “[Configure Input Signal](#)” once.

2. Each time you re-modify one of the settings, click the button to complete the configuration, otherwise the settings are invalid.

3. Other configuration menus also need to click “[Configure XXX XXX](#)”, otherwise the settings are invalid.

6.2.4 Reference and Frequency Sweep Configuration

Reference Signal Configuration:

The configuration area of reference signal is shown in the red box in Fig.65. The details of configuration are shown in Table 6.

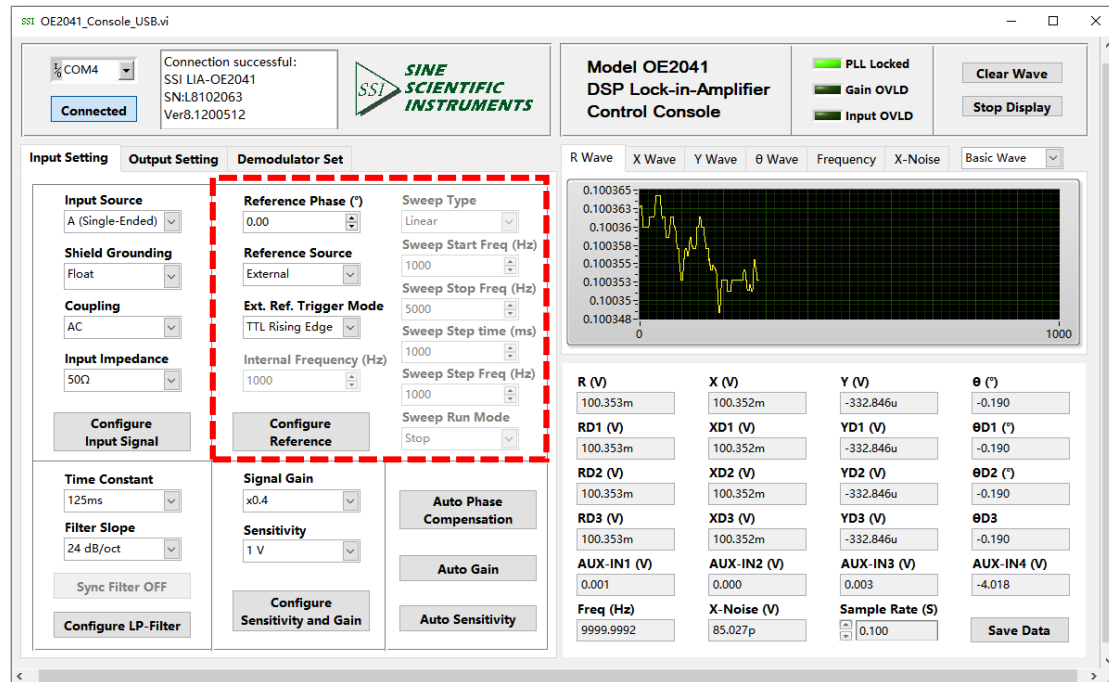

Fig.65 The Configuration Area of Reference Signal

Phase(°)	Setting the phase shift of two orthogonal reference signals for PSD algorithm. The range is -180° to $+180^{\circ}$ and the resolution is 0.01°
Reference Source	External
	Internal
	Internal Sweep
	Self Reference
External Ref Trigger	TTL Rising Edge
	Sine Zero Crossing
Int. Frequency	Manually, 1mHz to 60MHz by one-step of 1mHz at least.

Note that:

1. After finishing all the settings, click the button "Configure Reference" to finish the configuration for input signal. All settings can be changed at the same time and you just need to click the button once.
2. After changing the settings, you need to click "Configure Reference" to finish this configuration. Otherwise, the settings are void.

Frequency Sweep Configuration:

Choose the button "Internal Sweep" in "Reference Source" to configure internal frequency sweep as is shown in Fig.66. The details of configuration are shown in Table 7.

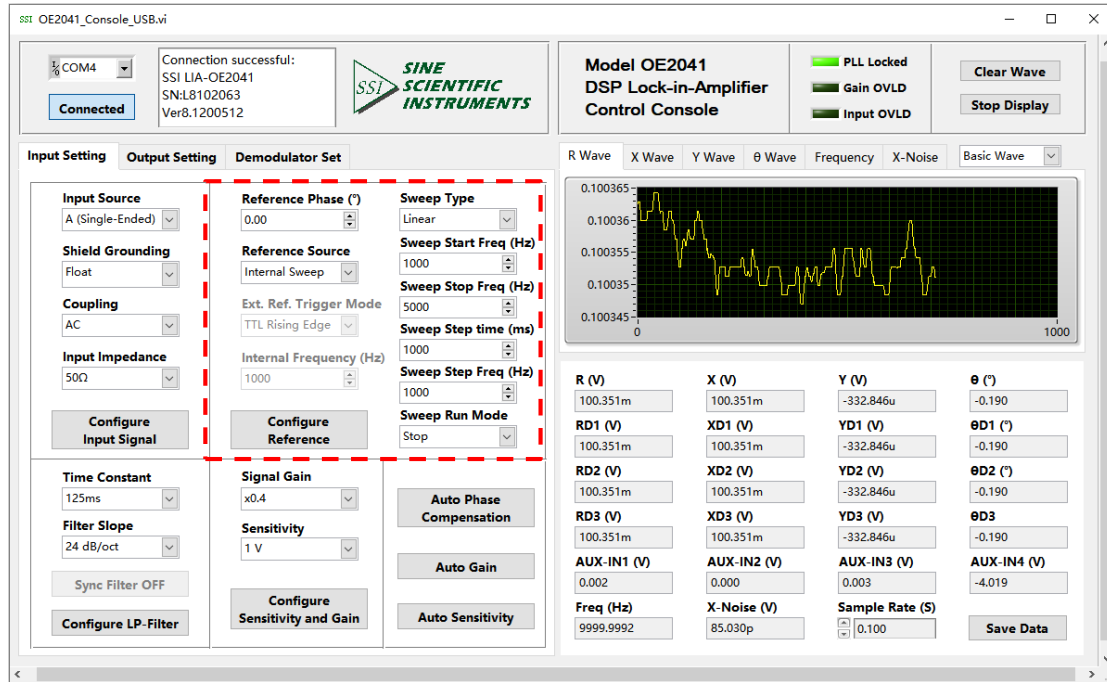

Fig.66 The Configuration Area of Internal Frequency Sweep

Sweep Type	Linear
Sweep Start Freq (Hz)	Log
Sweep Start Freq (Hz)	Setting the start frequency of sweep manually. The frequency range is from 1mHz to 60MHz and the minimum resolution is 1mHz.
Sweep Stop Freq (Hz)	Setting the stop frequency of sweep manually. The frequency range is from 1mHz to 60MHz and the minimum resolution is 1Hz.
Sweep Step Time (ms)	Setting the step time for every sweep manually. The step range is from 1ms to 100s and the minimum resolution is 1ms.
Sweep Step Freq (Hz)	Setting the step frequency for every sweep manually. The step range is from 1Hz to 60MHz and the minimum resolution is 1Hz.
Sweep Step Percent (%)	Setting the step percentage for every sweep manually. The step range is from 0.001% to 100% and the minimum resolution is 0.001%.
Int. Sweep Run Mode	Single
	Loop
	Stop

Note that:

After finishing all the settings, click the button **Configure Reference** to finish the configuration for input signal. All settings can be changed at the same time and you just need to click this button once.

6.2.5 Sensitivity and Gain Configuration

The configuration area of sensitivity and gain is in the red box in Fig.67. The details of configuration are listed on the Table 8.

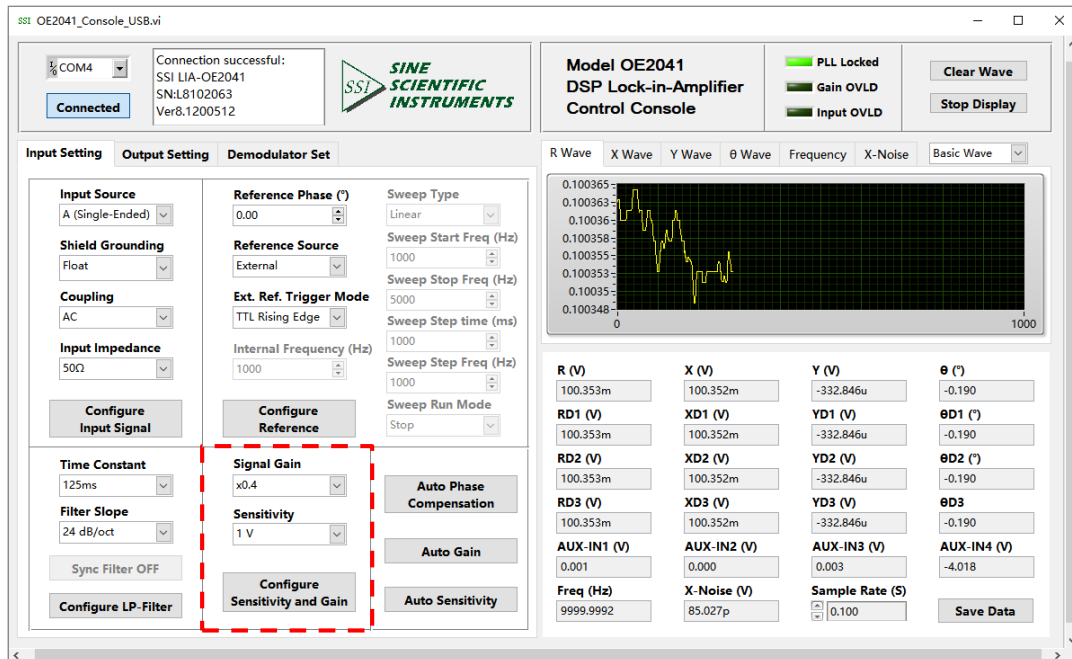

Fig.67 The Configuration Area of Sensitivity and Gain

Table 8. Sensitivity and Gain Configuration

Table 8. Sensitivity and Gain Configuration				
Signal Gain	0.4	2	8	40
	200	600	1500	
Sensitivity	1nV/fA	200nV/fA	50μV/pA	10mV/nA
	2nV/fA	500nV/fA	100μV/pA	20mV/nA
	5nV/fA	1μV/pA	200μV/pA	50mV/nA
	10nV/fA	2μV/pA	500μV/pA	100mV/nA
	20nV/fA	5μV/pA	1mV/nA	200mV/nA
	50nV/fA	10μV/pA	2mV/nA	500mV/nA
	100nV/fA	20μV/pA	5mV/nA	1V/μA

Note that:

1. After finishing all the settings, click the button "Configure Sensitivity and Gain" to finish the configuration for input signal. All settings can be changed at the same time and you just need to click this button once.
2. Once you change the settings, you need to click "Configure Sensitivity and Gain" to finish this configuration. Otherwise, the settings are void.

6.2.6 Auto Setting Configuration

The auto setting configuration is in the red box in the Fig.68. The details of configuration are shown in Table 9.

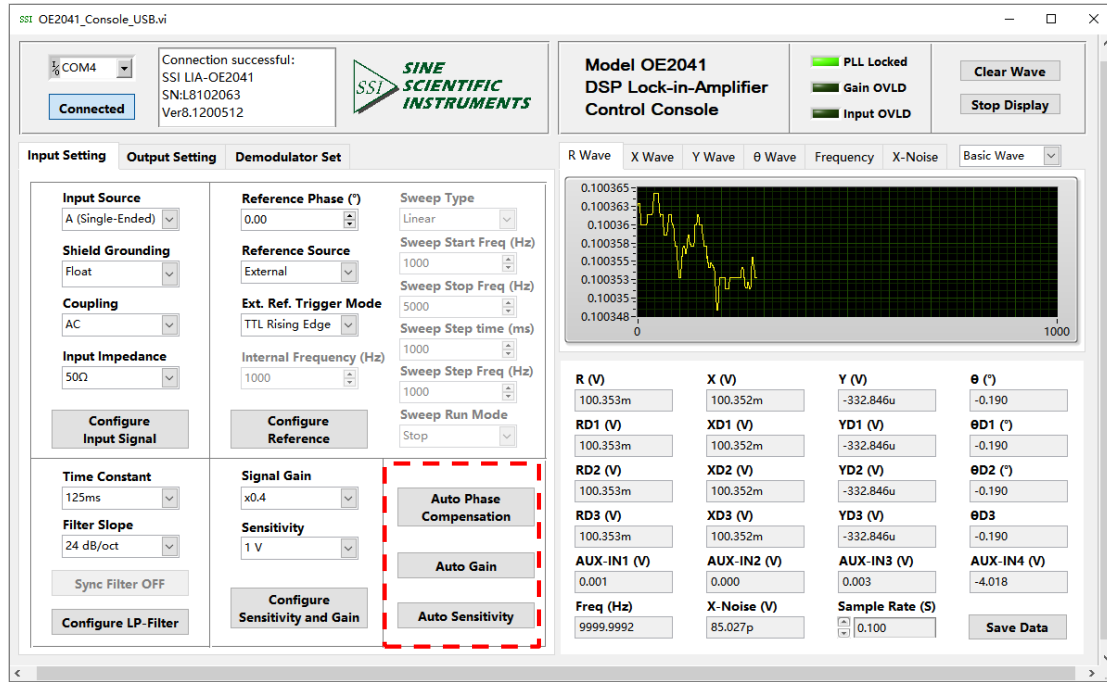

Fig.68 The Configuration Area of Auto Set Configuration

Table 9. Auto Setting Configuration Options	
Auto Phase Compensation	Disable / Enable
Auto Gain	Disable / Enable
Auto Sensitivity	Disable / Enable

Note that:

1. The configuration of "Auto Sensitivity", "Auto Dynamic Reserve", "Auto Phase Shift" and "Auto Range" is relatively independent, not through the "Configure XXX XXX" button in the other configuration area, but by clicking the button where the function is located to select the auto function. When the button is clicked, the button will change to "Processing", indicating that OE2041 is executing the automatic function, and when the execution is finished, the button will be reset to the initial state, and the "Signal Gain" and "Sensitivity" will be reset to the initial state. The "Signal Gain" and "Sensitivity" items will be updated to the values returned by OE2041.

6.2.7 Filter Configuration

The filter configuration is in the red box of the Fig.69. The details of configuration are listed on the Table 10.

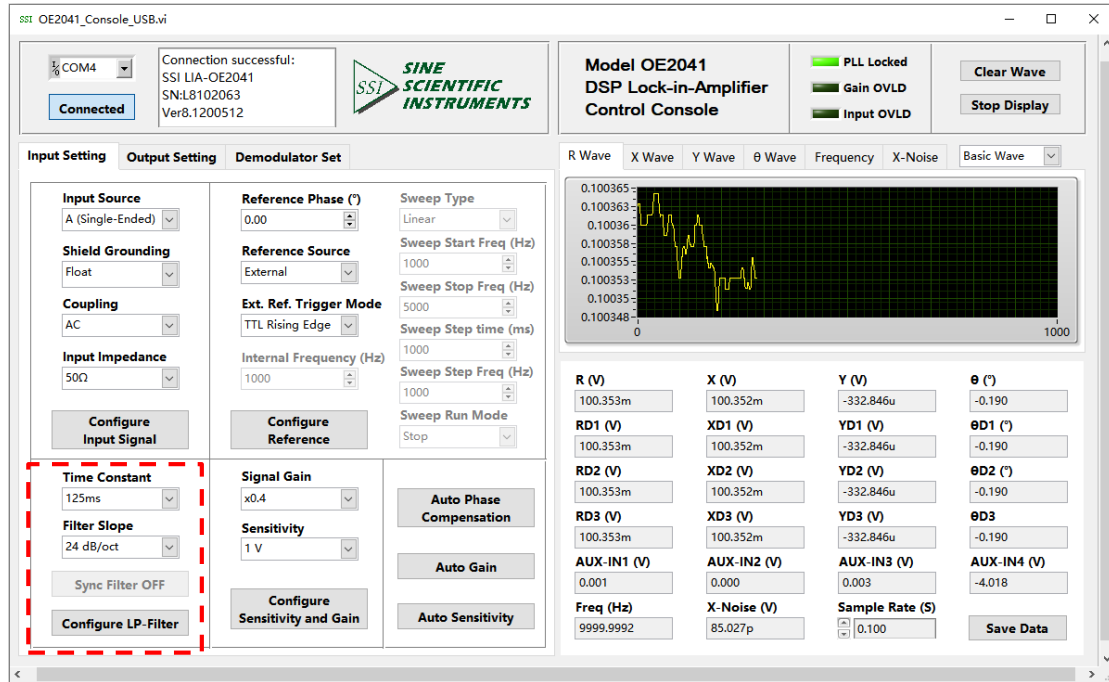

Fig.69 The Configuration Area of Filter

Table 10. Filter Configuration

Table 10. Filter Configuration				
Time Constant	30 ns	32 us	32 ms	35 s
	60 ns	65 us	65 ms	70 s
	125 ns	125 us	125 ms	140 s
	250 ns	250 us	250 ms	275 s
	500 ns	500 us	500 ms	550 s
	1 us	1 ms	1 s	1100 s
	2 us	2 ms	2 s	2200 s
	4 us	4 ms	4 s	4400 s
	8 us	8 ms	8 s	
	16 us	16ms	17 s	
Filter Slope	6 dB/oct			
	12 dB/oct			
	18 dB/oct			
	24 dB/oct			
	30 dB/oct			
	36 dB/oct			
	42 dB/oct			
48 dB/oct				
Sync Filter OFF/ON	Disable			
	Enable			

Note that:

1. After choosing all the settings, click the button “Configure LP-Filter” to finish the configuration. All settings can be changed at the same time and you just need to click this button once.
2. After changing the settings, you need to click this button to finish this configuration. Otherwise the settings are void.
3. The configurations of “Sync Filter OFF” is relatively independent. Click its own button but not the button “Configure LP-Filter” to disable or enable the auto function. The button will switch to “Sync Filter ON” when click the button. This means OE2041 is executing the auto function. If you need to disable the sync filter, click this button again and it will reset to the start status “Sync Filter OFF”. This means you have disabled the sync filter of OE2041 successfully.

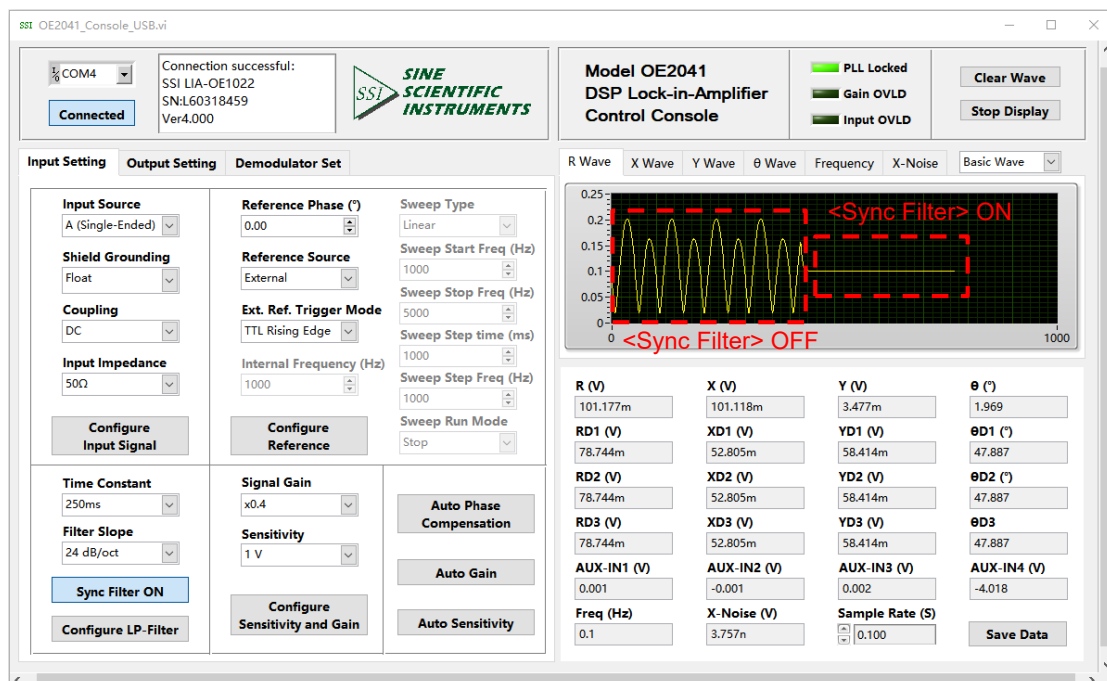

Fig.70 The Effect of Using Sync Filter

6.2.8 Output Configuration

The output configuration is in the red box of the Fig.71. The details of the configuration are listed in the Table 11.

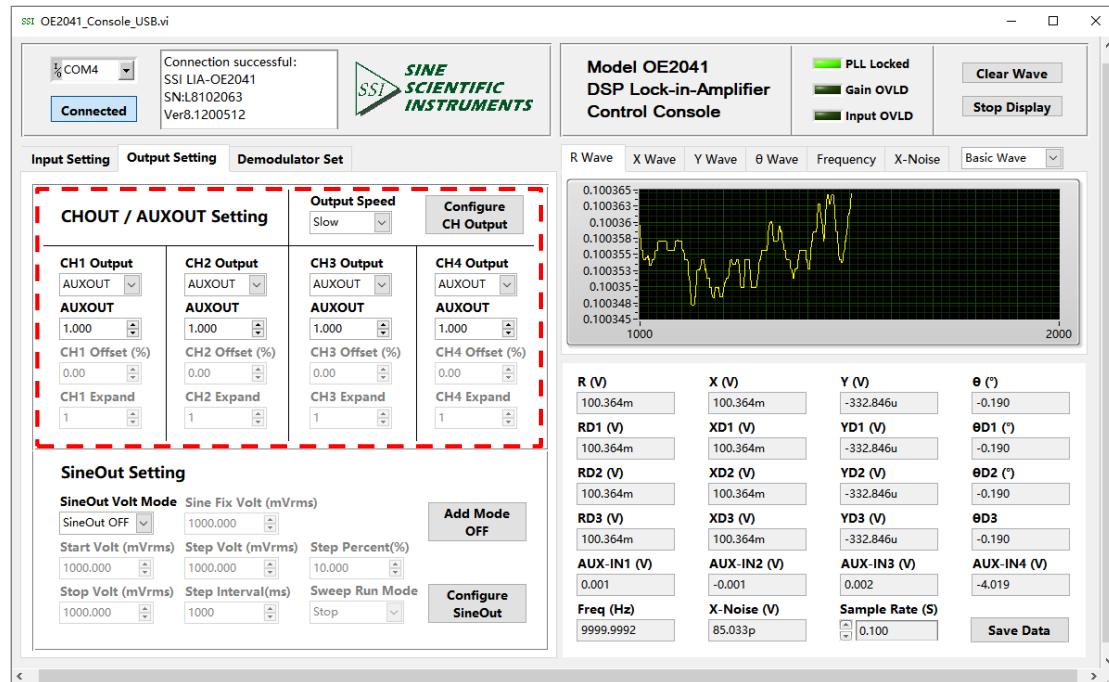

Fig.71 The Configuration Area of Output Channel

Table 11. Output Channels Configuration Options	
CH Output	Controlling the output channel CH1/CH2/CH3/CH4 on the front panel to output the value the user need, the value type includes AUXOUT custom value, X/Y/R/ θ value of signal and demodulation channel, input value of AUX-IN.
AUXOUT	Setting customized values of CH1~CH4 output from -10V to +10V.
CH Offset(%)	The range is -100% to +100%, the minimum step is 0.01%, 0.00% in default. All value besides AUXOUT can be set.
CH Expand	The range is 1~256, 1 in default. All value besides AUXOUT can be set.
Speed	Choosing "Fast" / "Slow". When choosing "Fast", the CH output channels can only output the R/X/Y value.

Note that:

1. After setting the output configuration of CH1 ~ CH4, click the button "Configure CH Output" to finish the configuration; all settings can be changed at the same time and you just need to click this button once.
2. After changing the settings, you need to click "Configure CH Output" to finish this configuration. Otherwise, the settings are void.

6.2.9 Sine Output Configuration

The sine output configuration is shown in the red box in Fig.72. Optional settings for users are

shown in table 12.

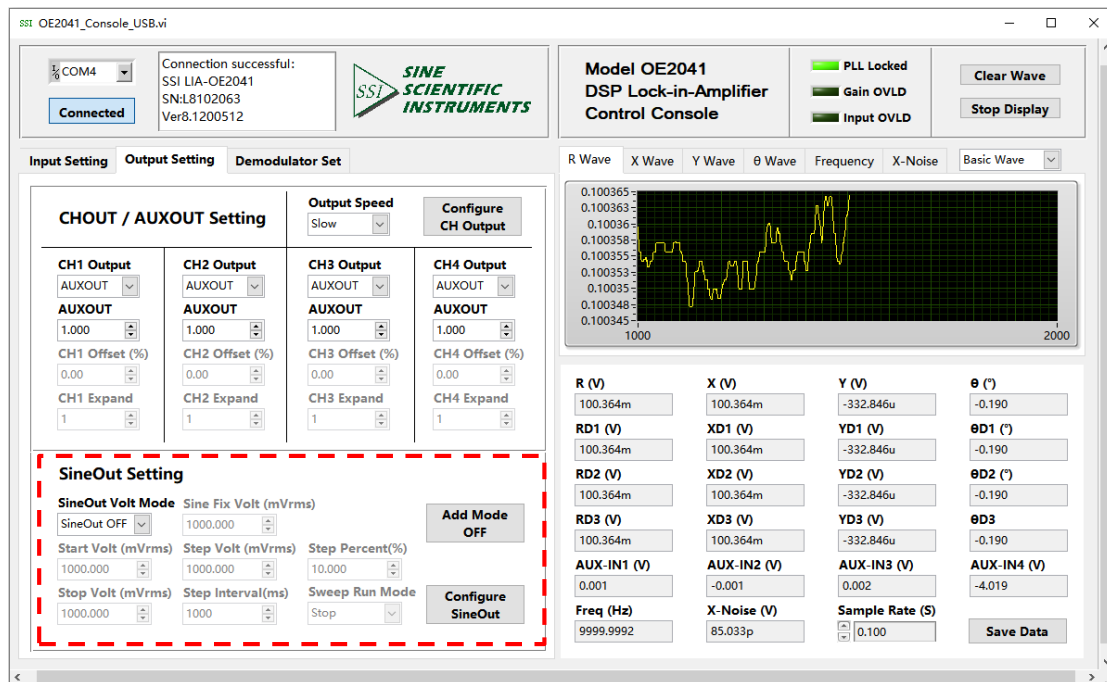

Fig.72 The Configuration Area of SINE OUTPUT

Table 12. SINE Output Configuration Options	
SineOut Mode	Sineout OFF
	Fixed
	Linear Sweep
	Log Sweep
Sine Fix Volt(mVrms)	This item can be operated when the sine output mode is selected as a fixed sine signal, manually entered by the user. The voltage range is from 0.001mVrms to 1000mVrms and the minimum resolution is 1 uVrms.
Start Volt(mVrms)	Setting the start value of sweep amplitude for every sweep manually. The voltage range is from 0.001mVrms to 1000mVrms and the minimum resolution is 1 uVrms.
Stop Volt(mVrms)	Setting the stop value of sweep amplitude for every sweep manually. The voltage range is from 0.001mVrms to 1000mVrms and the minimum resolution is 1 uVrms.
Step Interval(ms)	Setting the step time for every sweep manually. The time range is from 1ms to 100s and the minimum resolution is 1ms.
Step Volt(mVrms)	Setting the step voltage amplitude for every sweep manually. The voltage range is from 0.001mVrms to 1000mVrms and the minimum resolution is 1 uVrms.
Step Percent(%)	Setting the step percentage for every sweep manually. The step range is from 0.001% to 100% and the minimum

	resolution is 0.001%.
SineOut Run Mode	Single Loop Stop
Add Mode OFF/ON	Setting to turn OFF/ON the add function of the ADD-IN interface on the front panel.

Note that:

1. After setting the sine output configuration, click the button “Configure SineOut” to finish the configuration. All settings can be changed at the same time and you just need to click the button once.
2. After changing the settings, you need to click the button “Configure SineOut” to finish this configuration. Otherwise, the settings are void.
3. The configurations of “ADD Mode OFF” is relatively independent. Click its own button but not the button “Configure SineOut” to disable or enable the function.

6.2.10 Demodulator Configuration

The demodulator configuration is shown in the red box in Fig.73. The details of configuration are shown in Table 13.

The screenshot shows the 'Demodulator Setting' area highlighted with a red dashed box. It contains the following configuration options:

- Demod1 Mode:** Harmonic (dropdown)
- Demod2 Mode:** Harmonic (dropdown)
- Demod3 Mode:** Harmonic (dropdown)
- Harmonic 1:** 1 (spin box)
- Harmonic 2:** 1 (spin box)
- Harmonic 3:** 1 (spin box)
- Arbitrary Freq 1 (Hz):** 1000 (spin box)
- Arbitrary Freq 2 (Hz):** 1000 (spin box)
- Arbitrary Freq 3 (Hz):** 1000 (spin box)
- Equation1:** A=1, F1=1, B=1, F2=1
- Equation2:** A=1, F1=1, B=1, F2=1
- Equation3:** A=1, F1=1, B=1, F2=1

The 'System Setting' section includes a 'Default' dropdown, 'Recall Setting', and 'Save Setting' buttons.

The right side of the interface displays a graph of the demodulated signal and a table of measured values:

R (V)	X (V)	Y (V)	θ (°)
100.350m	100.349m	-332.846u	-0.190
RD1 (V)	XD1 (V)	YD1 (V)	θD1 (°)
100.350m	100.349m	-332.846u	-0.190
RD2 (V)	XD2 (V)	YD2 (V)	θD2 (°)
100.350m	100.349m	-332.846u	-0.190
RD3 (V)	XD3 (V)	YD3 (V)	θD3 (°)
100.350m	100.349m	-332.846u	-0.190
AUX-IN1 (V)	AUX-IN2 (V)	AUX-IN3 (V)	AUX-IN4 (V)
0.001	-0.001	0.002	-4.018
Freq (Hz)	X-Noise (V)	Sample Rate (S)	
9999.9992	85.027p	0.100	

Fig.73 The Configuration Area of Demodulator

Demod Mode	Harmonic Mode
	Arbitrary Freq Mode
	Equation Mode
Harmonic	Setting the harmonic orders. The setting range is from 1 to 32767 integer and the value is 1 in default, which is the signal fundamental wave.
Arbitrary Freq	Setting the arbitrary frequency value of demodulator manually. The frequency range is from 1 mHz to 60 MHz, and the minimum resolution is 1 mHz.
Equation= $A \times F1 + B \times F2$	Setting the equation elements value of demodulator manually. The range of A and B is from is from -32767 to 32767 integer. The range of F1 and F2 is from 1 mHz to 60 MHz, and the minimum resolution is 1 mHz.

Note that:

1. After setting the output configuration, click the button "Configure Demodulator" to finish the configuration. All settings can be changed at the same time and you only need to click this button once.
2. After changing the settings, you need to click the button "Configure Demodulator" to finish this configuration. Otherwise, the settings are void.

6.2.11 Save and Recall System Configurations

The configuration area of save and recall system configurations is shown in the red box in Fig.74.

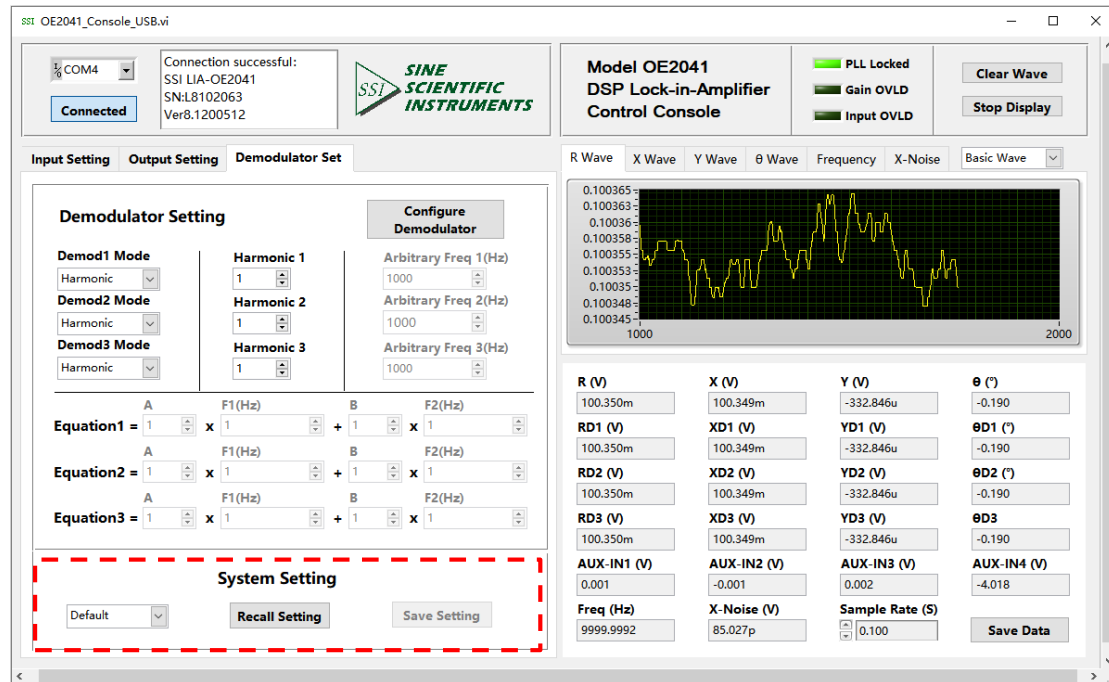

Fig.74 The Configuration Area of Save and Recall System Configurations

The left drop-down window in the red box selects “Default, S1, S2, S3, S4” five options, of which “Default” is the system default setting, for which only “Recall Setting” can be selected. “S1, S2, S3, S4” are four configuration saving area in the system, in which the current configuration can be saved. To overwrite the current configuration to the saving area, select one of “S1, S2, S3, S4” and click “Save Setting”. When need to recall the previously saved configuration, select the corresponding saving area and then click “Recall Setting”.

6.2.12 Data Storage

The software has the function of data storage. Users can choose to save the data or not that OE2041 collects in a period.

The saved data contains the R, X, Y, θ , frequency, and noise of the measured signal, the R, X, Y, θ of 3 demodulator channels, and the input signal value of 4 AUX-IN channels.

The steps for choosing to save data or not:

1. When the software is executing, click the button “Save Data” in the red box in Fig.75. After clicking this button and it displays “Saving...”. The software is saving the current collected data.
2. The data is saved in Excel. The file name is “Data_recorded_excel.xls”. It is saved in the program directory.
3. Click the button “Saving...” again, and the button status will switch back to “Save Data” again. This means the software stops saving collected data.

4. In box , you can modify the sampling rate of the current display and data storage. The input range is 0.001s ~ 100s.

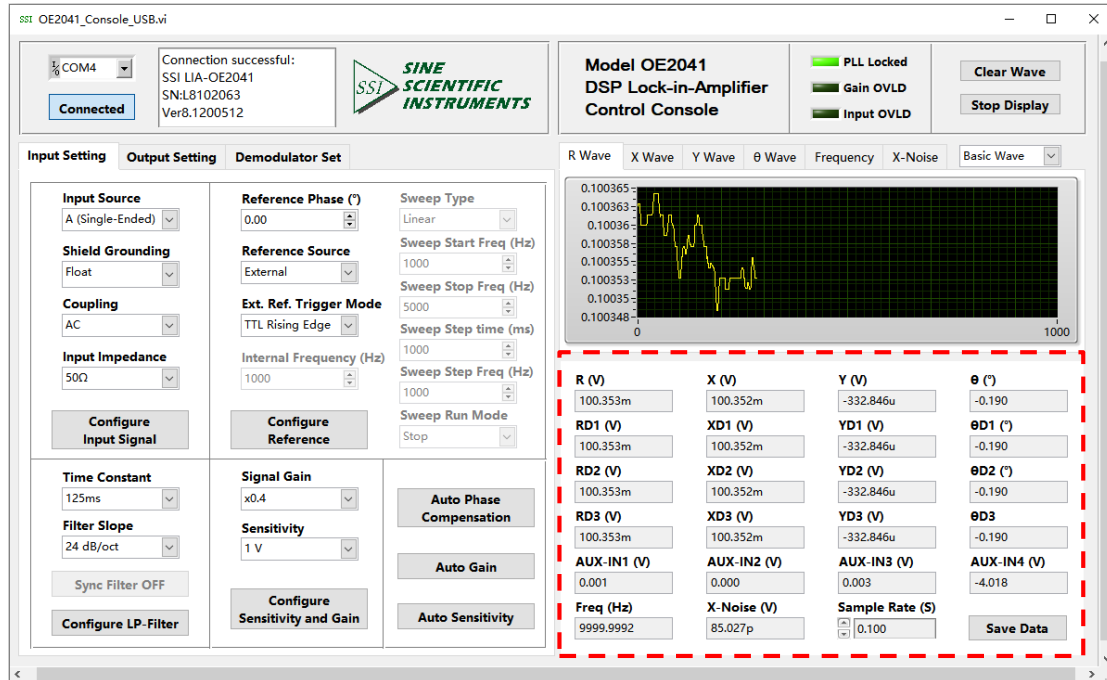

Fig.75 The Configuration Area of Data Storage

6.2.13 Waveform Display

The configuration area of waveform display is shown in the red box in Fig.76.

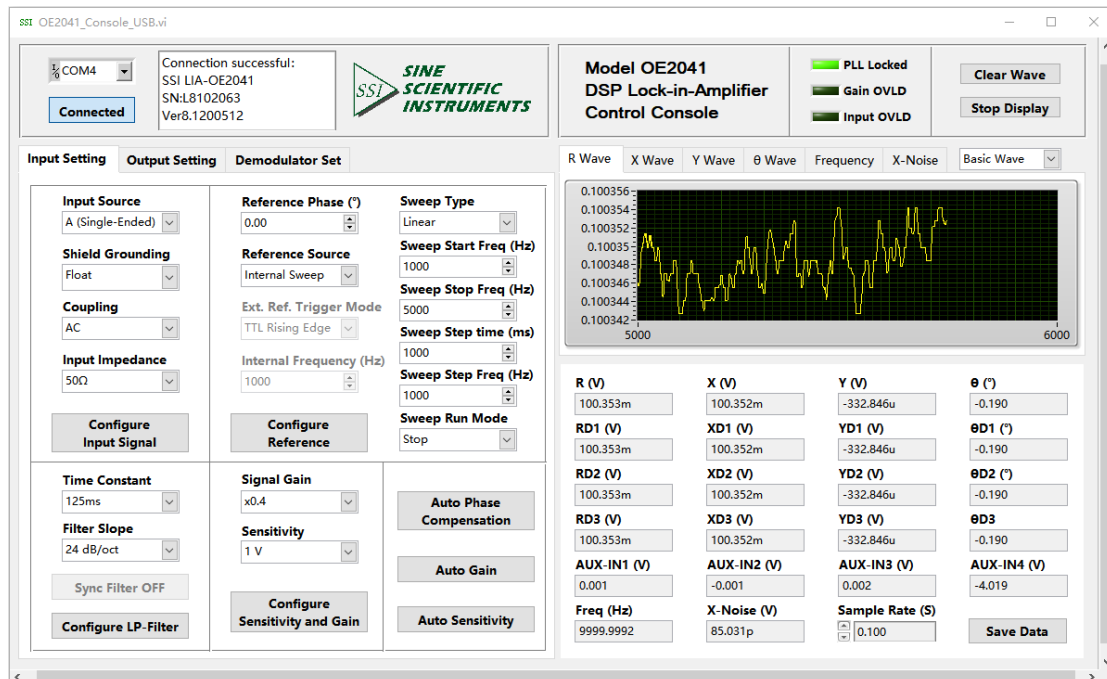

Fig.76 The Configuration Area of Wave Display

The data waveforms that can be displayed in the waveform display window include the R, X, Y, θ , frequency, and noise of the measured signal, the R, X, Y, θ of 3 demodulator channels, and the input signal value of 4 AUX-IN channels.

Different data waveforms can be selected via the tabs and drop-down windows above the red box.

6.3 Usage Examples

This example will show how to use OE2041 PC software to configure parameters, and observe and record the value of R, X, Y and θ .

First, connect OE2041 and PC according to the software usage guidance in 6.2 and then you can start to configure.

Suppose the user needs to make the following lock-in amplifier settings in Table 14 and perform data saving.

Input Source	Single-ended voltage input
Input Signal Size	40 mV
Input Impedance	50 Ω
Input Coupling	AC
Input Gain	Auto Gain
Sensitivity	Auto Sensitivity
Reference Source	External reference, 1000Hz
Reference Signal trigger way	TTL rising edge trigger
Phase Shift Angle	0°
Time Constant of Low Pass Filter	250 ms
Roll Off	24 dB/oct
Sampling Rate	1 s

The steps to finish the configurations in Table 14 are as follows:

1. According to Table 14, choose the following options in “Input Setting”, including “Input Source”, “Coupling” and “Input Impedance” with other options in default, as is shown in Fig.77. At last, click the button “**Configure Input Signal**” to finish the configurations.

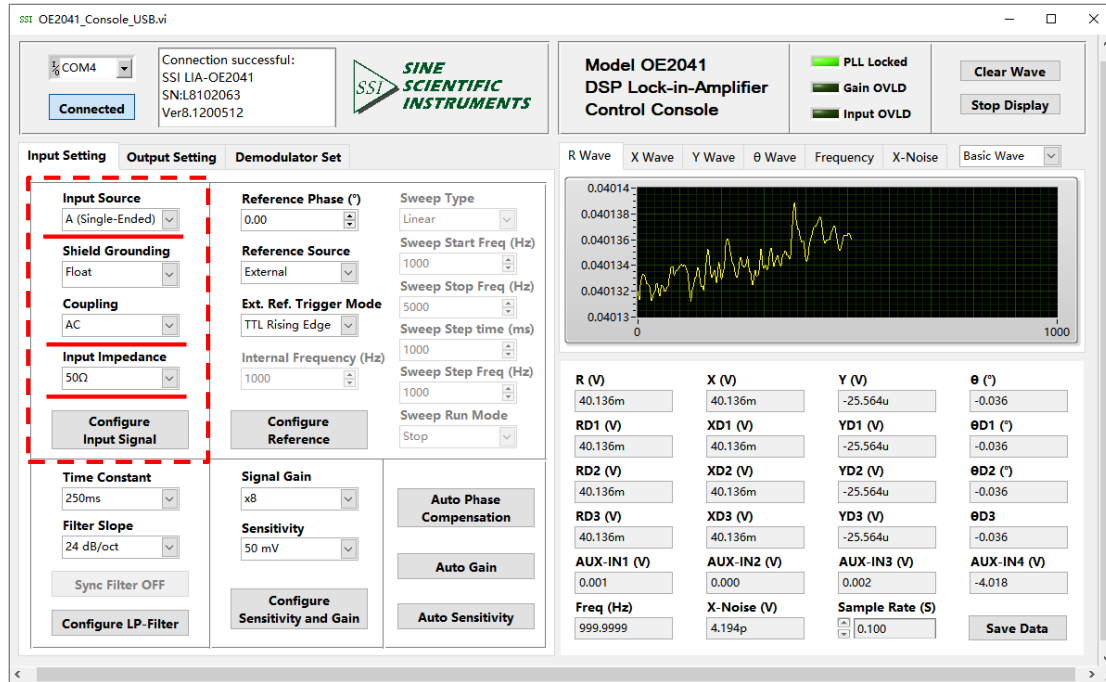

Fig.77 Input Configuration

2. Choose the following options in “Reference Configuration”, including “Reference Phase”, “Reference Source”, “Ext. Ref. Trigger Mode” with other options in default, as is shown in Fig.78. At last, click the button “Configure Reference” to finish the configurations.

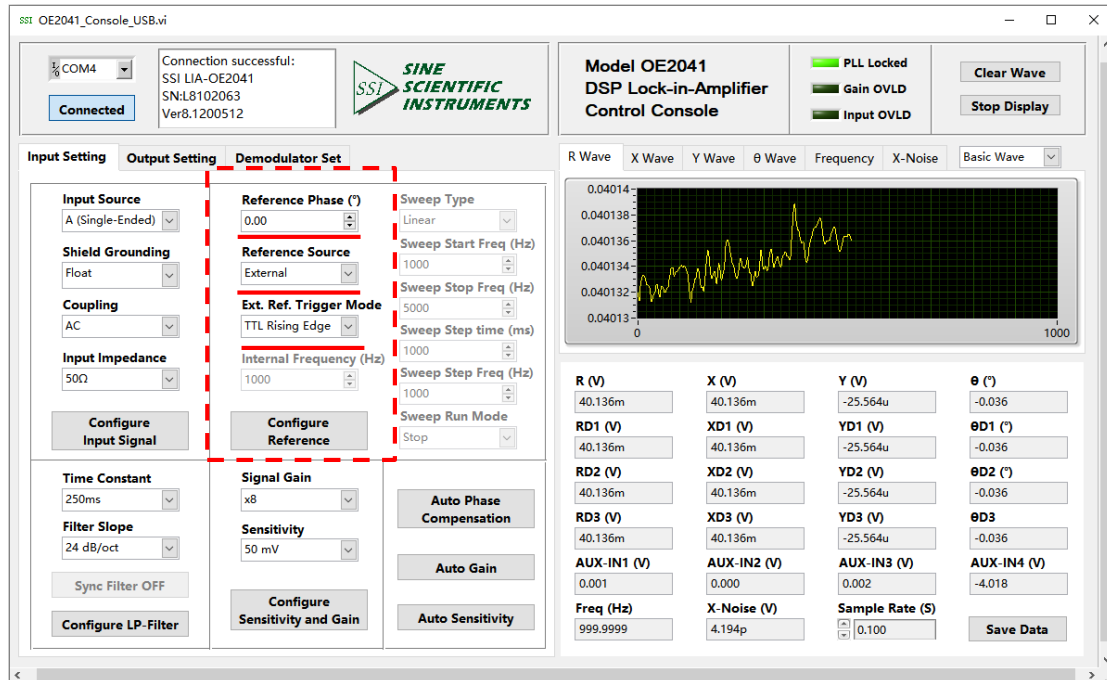

Fig.78 Reference Configuration

3. Choose these two options in “Filter Configuration”, including “Time Constant” and “Filter Slope” with other options in default, as is shown in Fig.79. At last, click the button “Configure

LP-Filter” to finish the configurations.

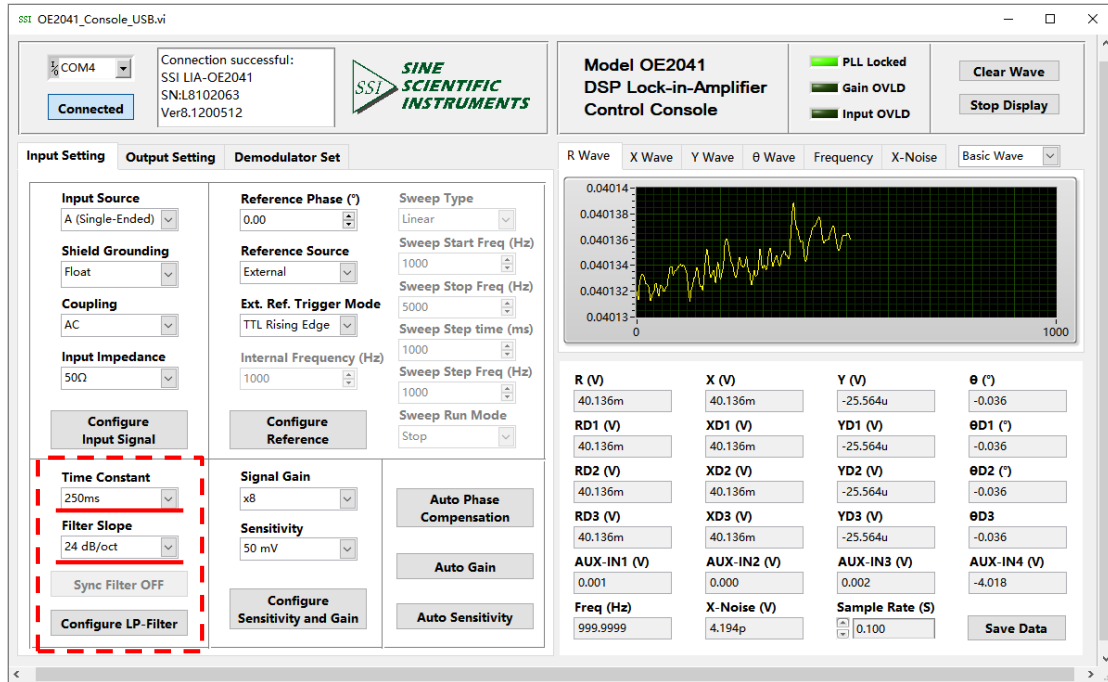

Fig.79 Filter Configuration

4. Choose these two options in “Sensitivity and Gain Configuration”, including “Signal Gain” and “Sensitivity” with other options in default, as is shown in Fig.80. At last, click the button “Configure Sensitivity and Gain” to finish the configurations.

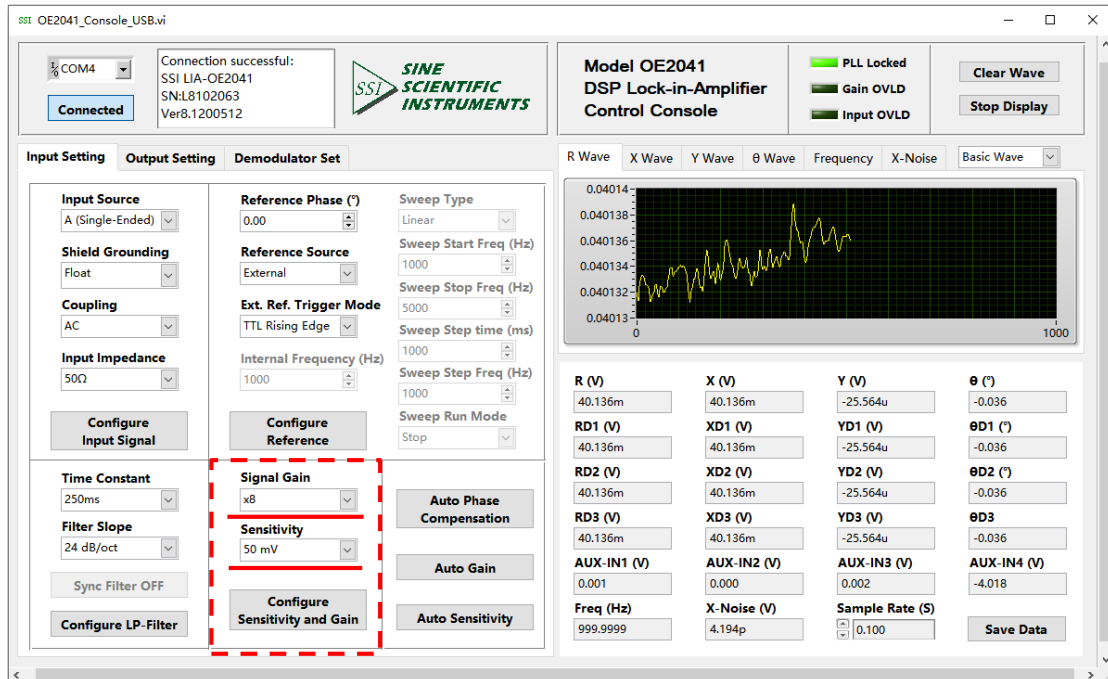

Fig.80 Sensitivity and Gain Configuration

In addition, since “Auto Sensitivity” and “Auto Gain” are selected to automatically set the full offset sensitivity, you only need to click the “Auto Sensitivity” and “Auto Gain” buttons respectively, and then the button will change to “Processing...”. When the execution is finished, the button will be reset to its initial state, and the “Gain” and “Sensitivity” will be updated to the values returned by OE2041.

At this point, look at the “Sensitivity” item on the main interface, and compare Fig.80 to find that Sensitivity has been changed to the appropriate sensitivity (from 1V to 50 mV); and Gain has been changed from 0.4 to 8 times, as shown in Fig.81.

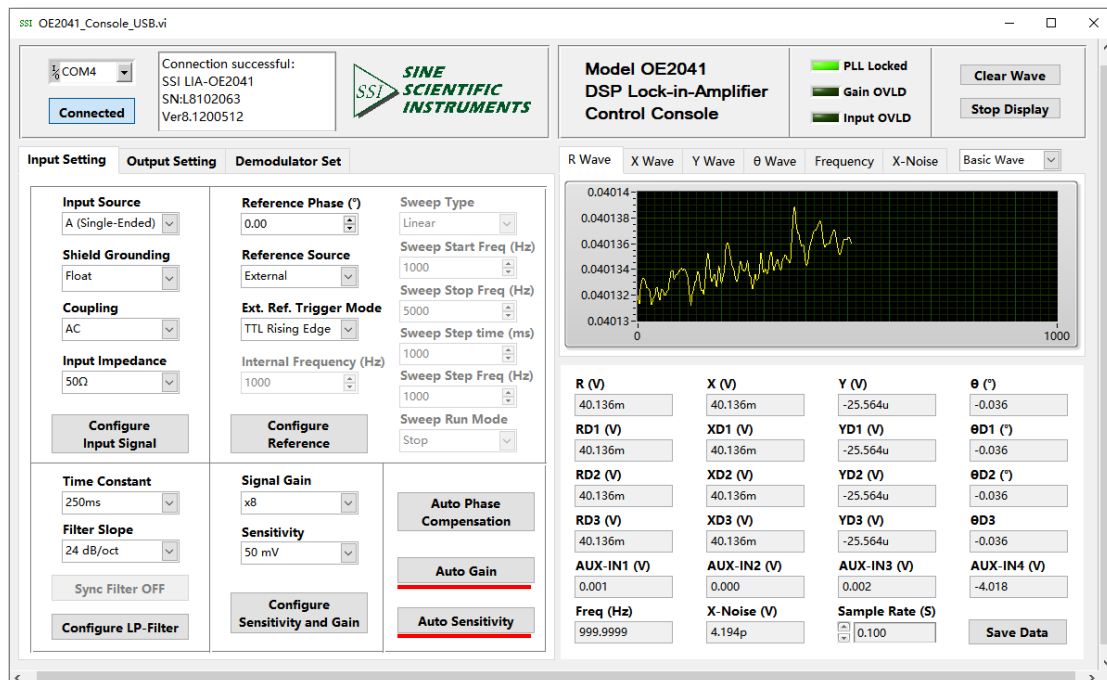

Fig.81 Auto Sensitivity and Gain Configuration

5. The configurations of OE2041 are finished. Other options are in default. Then users can collect and save data.

Data is saved in the selected directory in the form of an Excel. The file name is "Data_recorded_excel.xls" and it has 23 columns of data.

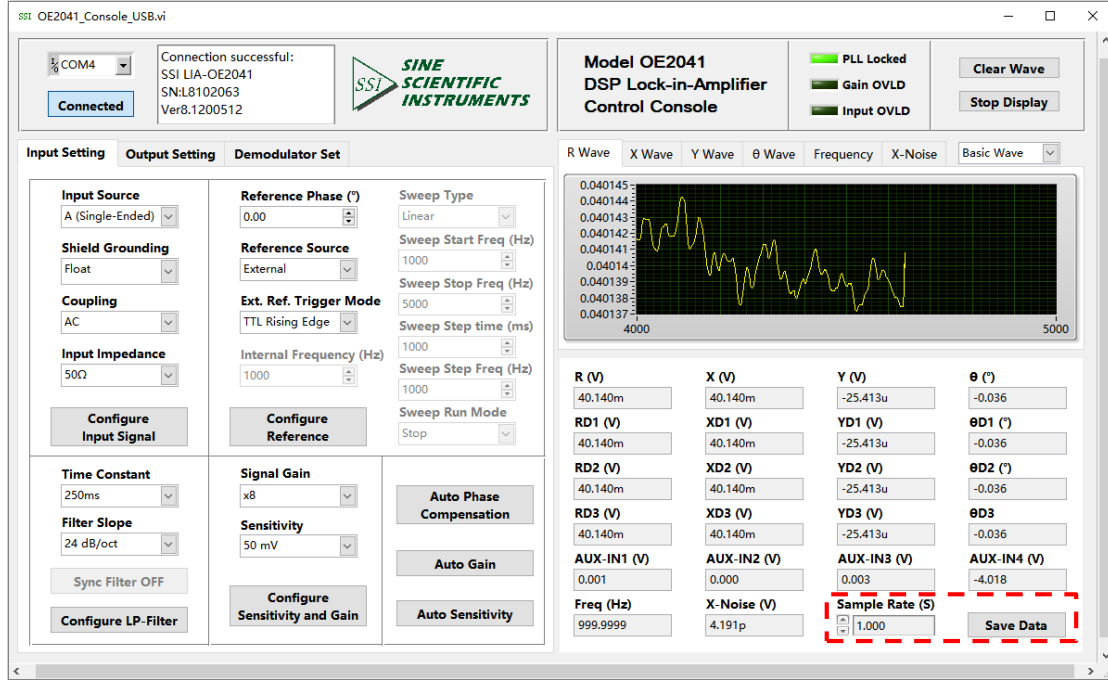

Fig.82 The data saving is paused

As is shown in Fig.81, click the button "Save Data" in the red box. When this button is clicked and it displays "Saving...". This means the OE2041 is saving data, as is shown in Fig.83.

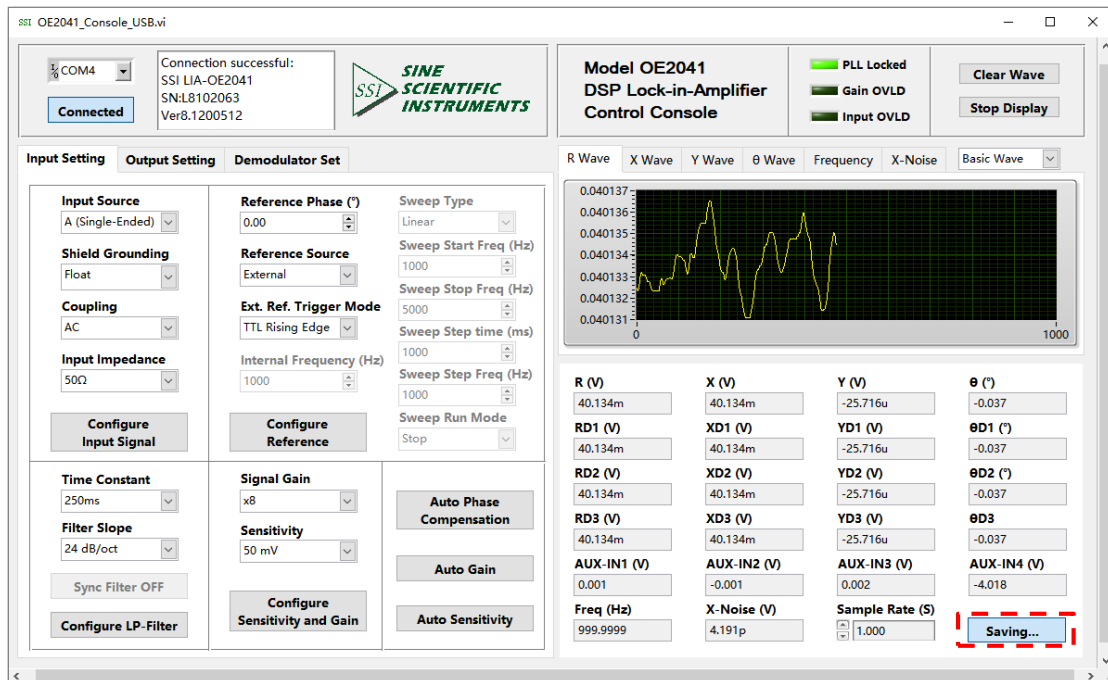

Fig.83 The data saving is executing

Excel file saved in current directory is as shown in Fig.84. Open the file and the data format is as shown in Fig.85.

Name	Date modified	Type	Size
Data_recorded_excel	2021-12-22 16:42	Microsoft Excel 97...	91 KB
OE2041_Console_EN.aliases	2021-04-16 9:57	ALIASES File	1 KB
OE2041_Console_EN	2021-04-16 9:57	Application	1,196 KB
OE2041_Console_EN	2021-04-16 9:57	Configuration sett...	1 KB

Fig.84 The Excel of Saved Data

A	B	C	D	E	F	G	H	I	J	K	L	M	N	O	P	Q	R	S	T	U	V	W	
1	2020/5/13	10:29:20	采样间隔: 1.000 s																				
2	X	Y	R	θ	XD1	YD1	RD1	θD1	XD2	YD2	RD2	θD2	XD3	YD3	RD3	θD3	XNoise	YNoise	Frequency	AUXADC1	AUXADC2	AUXADC3	AUXADC4
3	0.0401348	-2.56E-05	0.040135	-0.03649	0.040135	-2.56E-05	0.040135	-0.03649	0.040135	-2.56E-05	0.040135	-0.03649	0.040135	-2.56E-05	0.040135	-0.03649	4.19E-12	0	999.9999	0.000938	-0.00063	0.002188	-4.01825
4	0.0401349	-2.56E-05	0.040135	-0.03649	0.040135	-2.56E-05	0.040135	-0.03649	0.040135	-2.56E-05	0.040135	-0.03649	0.040135	-2.56E-05	0.040135	-0.03649	4.19E-12	0	999.9999	0.000938	-0.00031	0.001875	-4.01794
5	0.0401349	-2.56E-05	0.040135	-0.03649	0.040135	-2.56E-05	0.040135	-0.03649	0.040135	-2.56E-05	0.040135	-0.03649	0.040135	-2.56E-05	0.040135	-0.03649	4.19E-12	0	999.9999	0.000625	-0.00063	0.002188	-4.01762
6	0.0401349	-2.56E-05	0.040135	-0.03655	0.040135	-2.56E-05	0.040135	-0.03655	0.040135	-2.56E-05	0.040135	-0.03655	0.040135	-2.56E-05	0.040135	-0.03655	4.19E-12	0	999.9999	0.001563	-0.00031	0.002188	-4.01794
7	0.0401349	-2.56E-05	0.040135	-0.03661	0.040135	-2.56E-05	0.040135	-0.03661	0.040135	-2.56E-05	0.040135	-0.03661	0.040135	-2.56E-05	0.040135	-0.03661	4.19E-12	0	999.9999	0.00125	-0.00031	0.002188	-4.01762
8	0.040135	-2.56E-05	0.040135	-0.03661	0.040135	-2.56E-05	0.040135	-0.03661	0.040135	-2.56E-05	0.040135	-0.03661	0.040135	-2.56E-05	0.040135	-0.03661	4.19E-12	0	999.9999	0.00125	0	0.002188	-4.01762
9	0.040135	-2.56E-05	0.040135	-0.03661	0.040135	-2.56E-05	0.040135	-0.03661	0.040135	-2.56E-05	0.040135	-0.03661	0.040135	-2.56E-05	0.040135	-0.03661	4.19E-12	0	999.9999	0.000625	-0.00031	0.001875	-4.01762
10	0.040135	-2.56E-05	0.040135	-0.03661	0.040135	-2.56E-05	0.040135	-0.03661	0.040135	-2.56E-05	0.040135	-0.03661	0.040135	-2.56E-05	0.040135	-0.03661	4.19E-12	0	999.9999	0.000938	0	0.0025	-4.01731
11	0.0401351	-2.56E-05	0.040135	-0.03659	0.040135	-2.56E-05	0.040135	-0.03659	0.040135	-2.56E-05	0.040135	-0.03659	0.040135	-2.56E-05	0.040135	-0.03659	4.19E-12	0	999.9999	0.001563	0.000313	0.001875	-4.01981
12	0.0401351	-2.56E-05	0.040135	-0.03652	0.040135	-2.56E-05	0.040135	-0.03652	0.040135	-2.56E-05	0.040135	-0.03652	0.040135	-2.56E-05	0.040135	-0.03652	4.19E-12	0	999.9999	0.00125	0	0.002813	-4.01669
13	0.0401352	-2.56E-05	0.040135	-0.03649	0.040135	-2.56E-05	0.040135	-0.03649	0.040135	-2.56E-05	0.040135	-0.03649	0.040135	-2.56E-05	0.040135	-0.03649	4.19E-12	0	999.9999	0.000938	0.000313	0.001875	-4.01825
14	0.0401354	-2.56E-05	0.040135	-0.03645	0.040135	-2.56E-05	0.040135	-0.03645	0.040135	-2.56E-05	0.040135	-0.03645	0.040135	-2.56E-05	0.040135	-0.03645	4.19E-12	0	999.9999	0.000938	-0.00031	0.001875	-4.01794
15	0.0401355	-2.56E-05	0.040136	-0.03638	0.040136	-2.56E-05	0.040136	-0.03638	0.040136	-2.56E-05	0.040136	-0.03638	0.040136	-2.56E-05	0.040136	-0.03638	4.19E-12	0	999.9999	0.000625	-0.00063	0.001875	-4.01887
16	0.0401357	-2.56E-05	0.040136	-0.03629	0.040136	-2.56E-05	0.040136	-0.03629	0.040136	-2.56E-05	0.040136	-0.03629	0.040136	-2.56E-05	0.040136	-0.03629	4.19E-12	0	999.9999	0.00125	-0.00031	0.001875	-4.01856
17	0.0401359	-2.56E-05	0.040136	-0.03622	0.040136	-2.56E-05	0.040136	-0.03622	0.040136	-2.56E-05	0.040136	-0.03622	0.040136	-2.56E-05	0.040136	-0.03622	4.19E-12	0	999.9999	0.000938	-0.00031	0.002188	-4.01825
18	0.0401359	-2.56E-05	0.040136	-0.03622	0.040136	-2.56E-05	0.040136	-0.03622	0.040136	-2.56E-05	0.040136	-0.03622	0.040136	-2.56E-05	0.040136	-0.03622	4.19E-12	0	999.9999	0.000938	-0.00031	0.001875	-4.01794
19	0.040136	-2.56E-05	0.040136	-0.03622	0.040136	-2.56E-05	0.040136	-0.03622	0.040136	-2.56E-05	0.040136	-0.03622	0.040136	-2.56E-05	0.040136	-0.03622	4.19E-12	0	999.9999	0.00125	0	0.002188	-4.01762
20	0.0401359	-2.56E-05	0.040136	-0.03622	0.040136	-2.56E-05	0.040136	-0.03622	0.040136	-2.56E-05	0.040136	-0.03622	0.040136	-2.56E-05	0.040136	-0.03622	4.19E-12	0	999.9999	0.00125	-0.00031	0.002188	-4.01794
21	0.0401359	-2.56E-05	0.040136	-0.03627	0.040136	-2.56E-05	0.040136	-0.03627	0.040136	-2.56E-05	0.040136	-0.03627	0.040136	-2.56E-05	0.040136	-0.03627	4.19E-12	0	999.9999	0.000938	0	0.002188	-4.01794
22	0.0401358	-2.56E-05	0.040136	-0.03629	0.040136	-2.56E-05	0.040136	-0.03629	0.040136	-2.56E-05	0.040136	-0.03629	0.040136	-2.56E-05	0.040136	-0.03629	4.19E-12	0	999.9999	0.000938	0	0.002188	-4.01919
23	0.0401356	-2.56E-05	0.040136	-0.03634	0.040136	-2.56E-05	0.040136	-0.03634	0.040136	-2.56E-05	0.040136	-0.03634	0.040136	-2.56E-05	0.040136	-0.03634	4.19E-12	0	999.9999	0.00125	0	0.0025	-4.01981
24	0.0401355	-2.56E-05	0.040135	-0.03642	0.040135	-2.56E-05	0.040135	-0.03642	0.040135	-2.56E-05	0.040135	-0.03642	0.040135	-2.56E-05	0.040135	-0.03642	4.19E-12	0	999.9999	0.00125	-0.00031	0.001875	-4.01919
25	0.0401353	-2.56E-05	0.040135	-0.03649	0.040135	-2.56E-05	0.040135	-0.03649	0.040135	-2.56E-05	0.040135	-0.03649	0.040135	-2.56E-05	0.040135	-0.03649	4.19E-12	0	999.9999	0.000938	-0.00063	0.002188	-4.0195

Fig.85 Data format of Data_recorded_excel.xls

7. PERFORMANCE TESTS

Introduction

The performance tests are designed for users to prove that the OE2041 can operate normally and enhance users' confidence to our instrument. Each test can be recorded on the Performance Test Record form at the final section of this chapter.

Serial Number

If you have any questions and need to contact us, please offer the serial number of your instrument. You can find the serial number on the CD box, the package box or the backside of your instrument. You can also check the serial number at <INFO> on the screen when the instrument is powered on.

Firmware Revision

The firmware revision number is shown at <INFO> on the screen when the instrument is powered on.

Warm Up

Due to the temperature drift of chips, it is best to warm up the instrument for some time (30~60 Minutes) in order to reduce measurement error.

Test Record

At the end of this section, there is a performance test record. It is necessary to make a copy of it before filling in the record. This record will allow you to determine whether the tests pass or fail. Please keep the

record for future contact with our engineers.

If a Test Fails

If a test fails, you should check the settings and connections of any external equipment and internal equipment. After checking the settings, repeat this test from warm up and make sure that the test is performed correctly. If possible, replace other external devices and test again.

If the test continues to fail, contact us for further instructions. Make sure that you have the unit's serial number and firmware revision code handy. Have the test record on hand as well.

Necessary Equipment

The following equipment is necessary to complete the performance tests. The suggested equipment or its equivalent should be used.

1. Function Signal Generator

Freq Range	1 Hz to 100 MHz
Freq Accuracy	Better than 5 ppm
Amplitude Accuracy	0.2 dB from 1 Hz to 60 MHz
Spurious	≤ -55 dBc
TTL SYNC	Available
Output Setup	50 Ω or High Z
Recommended	AGILENT 33250A

2. Digital Voltmeter

Voltage Range	≥ 20 V, 4 1/2 digits
Accuracy	≤ 0.005 %
Recommended	KEITHLEY 2100

3. DC Voltage Source

Voltage Range	≥ 10 V
Accuracy	< 10 mVpp
Recommended	RIGOL DP831A

4. Connector

BNC Terminations	50 Ω
T-type BNC Connector	

Front Panel Display Test

First, turn on the power switch on the rear panel to start the device. Second, check whether the display is lighted or not. Third, check whether there are bad pixels on the display. End the display test.

Keypad Test

After the device is started, press any button and you will hear "Di" sound once. Then, try to press every button to check whether the display change to the corresponding setting. Finally, press <Sensitivity> and spin the knob to check whether the knob is OK.

7.1 Starting Test

The starting test checks the lock-in hardware. This test should be done before any other performance tests.

Device

No external device is required in this test.

Steps

1. Open the power switch on the rear panel to start the lock-in amplifier.
2. Observe the device, and check whether the screen, keyboard and cooling fan is OK.
3. Record the test results in the Performance Test Record.

7.2 DC Offset

This test measures the DC offset of the input.

Device

Connect a 50Ω BNC termination to the A input. This shorts the input so the lock-in's own DC offset will be measured.

Steps

1. Turn the lock-in off and on to restart it. Recall the <Default> settings in <Recall>.
2. Press the buttons in the following sequence:
 - <Ref. Source> Set to <Internal>
 - <Ref. Frequency> Set to 1Hz
 - <Sensitivity> Set to <1mV> through the spinning knob
 - <Gain> Set to <600> through the spinning knob
3. Wait 10 seconds, then record the value of R.
4. Change the setting:
 - <Coupling> Set to <DC>
5. Wait 10 seconds, then record the value of R.
6. End the test and fill the result into the performance test form.

7.3 Common Mode Rejection

This test measures the common mode rejection of the lock-in.

Device

Use the internal oscillator sine output to provide the signal.
Connect the [SINE OUT] to both A and B inputs of the lock-in.

Use equal length cables from A and B to a BNC TEE.

Connect the cable from the [SINE OUT] to the TEE. Do not use any termination.

Steps

1. Turn the lock-in off and on to restart it. Recall the <Default> settings in <Recall>.
2. Press the buttons in the following sequence:
 - <Sensitivity> Set to <1 V> through the spinning knob
 - <Ref. Source> Set to <Internal>
 - <Ref. Frequency> Set to 100 Hz
3. Wait until <R> is steady and <R> should be 1.000Vrms (within 3% error)
4. Press the buttons in the following sequence:
 - <Coupling> Set to <DC>
 - <Source> Set to <A-B>
 - <Sensitivity> Set to <10mV> through the spinning knob
5. Wait 10 seconds, and then record the value of R.
6. End the test. The common mode rejection equals to $20\lg(1/R)$, where R is in Volts(V).
Fill the results in the performance test form.

7.4 Amplitude Accuracy and Flatness

This test measures the amplitude accuracy and frequency response.

Device

Use the function signal generator to provide an accurate frequency and a sine wave.

Use one cable with BNC connector to connect the output of the function signal generator to the A input of the lock-in. Use another cable with BNC connector to connect the reference output of the function signal generator to the REF IN of the lock-in.

Set the function signal generator to:

Function	Sine
Frequency	1 kHz
Amplitude	1 Vrms
Offset	0 V
Output	50 Ω
Sweep	off
Modulation	none

Steps

1. Turn the lock-in off and on to restart it. Recall the <Default> settings in <Recall>.
2. Press the buttons in the following sequence:
 - <Filter dB/oct> Set to 24 dB/oct

<Impedance> Set to 50Ω

3. Amplitude accuracy is verified at 1kHz and various sensitivities. Set the sensitivity of the lock-in and the amplitude of the function signal generator in the following sequence:

Sensitivity	Amplitude
1 V	1.0000 Vrms
200 mV	200.00 mVrms
100 mV	100.00 mVrms
20 mV	20.000 mVrms
10 mV	10.000 mVrms

- Set the function signal generator to the amplitude shown above.
- Set <Sensitivity> of the lock-in.
- Wait 10 seconds, then record <R>, then test the next group of the sensitivity-amplitude.
- Repeat the steps from 3)-a) to 3)-c) until the Sensitivity-Amplitude test is completed.

4. Frequency response is checked at frequencies above 1kHz. Set the frequency in the following sequence:

Test Frequency
24 kHz
240 kHz
2.4 MHz
24 MHz

- Set <Sensitivity> of the lock-in to <200 mV>.
- Set the frequency of the function signal generator to 1 kHz and the amplitude to 200.00mVrms.
- Set the frequency of the function signal generator in the upper sequence.
- Wait 10 seconds, then record <R>, then test the next frequency.
- Repeat from 4)-c) to 4)-d) until all the frequencies are tested over.

5. End the test and fill the results in the performance test form.

7.5 Amplitude Linearity

This test measures the amplitude linearity. It tests how accurately the lock-in measures a signal smaller than full scale.

Device

Use a function signal generator to provide an accurate frequency and a sine wave.

Use a cable with BNC connector to connect the output of the function signal generator to the A input of the lock-in. Use another cable with BNC connector to connect the reference

output of the function signal generator to the REF IN of the lock-in.

Set the function signal generator to:

Function	Sine
Frequency	1 kHz
Amplitude	1 Vrms
Offset	0 V
Output	50 Ω
Sweep	off
Modulation	none

Steps

1. Turn the lock-in off and on to restart it. Recall the <Default> settings in <Recall>.
2. Press the buttons in the following sequence:
 - <Filter dB/oct> Set to 24 dB/oct
 - <Impedance> Set to 50 Ω
 - <Sensitivity> Set to <1V> through the spinning knob
3. The Amplitude of the function signal generator should be 1kHz at various amplitudes. Set the amplitude in the following sequence:

Amplitude
1.0000 Vrms
100.00 mVrms
10.000 mVrms

- a) Set the output amplitude of the function signal generator.
 - b) Wait 10 seconds, then record <R>, then test next amplitude.
 - c) Repeat from 3)-a) to 3)-b) until all amplitudes are tested over.
4. End the test and fill the results in the performance test form.

7.6 Frequency Accuracy

This test measures the frequency accuracy of the lock-in.

Device

Use the function signal generator to provide the reference signal.

Use one cable with BNC connector to connect the reference signal of the function signal generator to the REF IN of the lock-in.

Steps

1. Turn the lock-in off and on to restart it. Recall the <Default> settings in <Recall>.
2. Set the frequency of the function signal generator to 10 MHz.
3. Wait until <PLL: UNLOCK> changes to <PLL: LOCKED>, then record <Freq>.
4. End the test and fill in the performance test form.

7.7 Sine Output Amplitude Accuracy and Flatness

This test measures the amplitude accuracy and frequency response of the internal oscillator SINE OUT.

Device

Use a 1-meter length cable with BNC connector to connect the SINE OUT to the A of the lock-in.

Steps

1. Turn the lock-in off and on to restart it. Recall the <Default> settings in <Recall>.
2. Press the buttons in the following sequence:
 - <Sensitivity> Set to <1V> through the spinning knob
 - <Impedance> Set to 50 Ω
 - <Ref.source> Set to <Internal>
3. The frequency of the internal oscillator should be 1kHz steadily. Set <Sensitivity> and the amplitude of the SINE OUT in the following sequence:

Sensitivity	Sine Output Fixed Voltage
1 V	0.800 Vrms
200 mV	0.160 Vrms
50 mV	0.040 Vrms
10 mV	0.008 Vrms

- a) Set the amplitude of <SINE OUT>.
 - b) Set <Sensitivity>.
 - c) Wait 10 seconds, then record <R>, then test next group of Sensitivity-Sine Output.
 - d) Repeat from 3)-a) to 3)-c) until all the Sensitivity-Sine Output are tested over.
4. Frequency response is checked at frequencies above 1 kHz. Set <Ref. Frequency> in the following sequence:

Test Frequencies

24 kHz
240 kHz
2.4 MHz
24 MHz

- a) Set <Sensitivity> to <1 V>.
 - b) Set the amplitude of the <Sine Output> to 1Vrms.
 - c) Set <Ref. Frequency> in the upper sequence.
 - d) Wait 10 seconds, then record <R>, then test next frequency.
 - e) Repeat from 4)-c) to 4)-d) until all the frequencies are tested over.
5. End the test and fill results in the performance test form. Note that because of the 50 Ω resistor at the Sineout output, 50 Ω input impedance of A port will reduce the measured

amplitude by half.

7.8 DC Outputs and Inputs

This test measures the DC accuracy of the DC outputs and inputs of the lock-in.

Device

Use a linear DC regulator to generate a DC input.

Use a DVM to measure the DC output of the lock-in.

Steps

1. Turn the lock-in off and on to restart it. Recall the <Default> settings in <Recall>.
2. Press the buttons in the following sequence:
 - <Ref.source> Set to <Internal>
 - <CH Source> Set the source of 4 CH channels to <R>

3. Follow the steps below:

- a) Use a cable to connect CHOUT1 of the lock-in to the DVM. Set the DVM to 19.999 V range.
- b) Set <Offset> of <CHOUT> in the following sequence:

Offset (%)
100.00
50.00
0.00
-50.00
-100.00

- c) Waiting for 10 seconds and record the reading of the DVM. Then, test next group data.
 - d) Repeat steps 3-b) to 4-c) until finishing the tests for CH1. Then, connect the DVM to CH2, CH3 and CH4 and continue to finish the tests for CH2, CH3 and CH4.
4. Follow the steps below:
 - a) use signal cable to connect the DVM to the CHOUT of the lock-in.
 - b) set the source of 4 CH channels to <R> in <CH Source>.
 - c) set the value of <AUXOUT> in the following sequence:

AUXOUT (V)
10.000
5.000
0.000
-5.000
-10.000

- d) Wait 10 seconds and record the reading of the DVM. Then, test next group data.
- e) Repeat steps 3b to 3d until finishing the tests for AUXOUT1. Then connect the DVM to AUXOUT2, AUXOUT3 and AUXOUT4 to finish the tests for AUXOUT2, AUXOUT3 and AUXOUT4.

5. Follow the steps below:
 - a) Set <Monitor> in <Display> to <Input>.
 - b) use signal cable to connect the DC regulator OUT to AUX_IN1 on the rear panel of the lock-in.
 - c) set the output voltage of the DC regulator in the following sequence

Voltage (V)

10.000

5.000

0.000

-5.000

-10.000

- d) Wait 10 seconds and recode the reading of <AUX-IN1> at the top of the screen. Then, test the next group data.
 - e) Repeat steps 4c to 4d until finishing the tests for AUX-IN1. Then connect the DC regulator OUT to AUX-IN2, AUX-IN3 and AUX-IN4 and finish the tests for AUX-IN2, AUX-IN3 and AUX-IN4.
6. End the tests for DC inputs and outputs and fill the results in the performance test record form.

7.9 Input Noise

This test measures the input noise of the lock-in.

Device

After the system itself is grounded, the lock-in can measure its own input noise.

Steps

1. Turn the lock-in off and on to restart it. Recall the <Default> settings in <Recall>.
2. Set the parameters in the following sequence:

<Ref. Source>	Set to <Internal>
<Ref. Frequency>	Set to 997 Hz
<Sensitivity>	Set to <50 nV> through the spinning knob
<Gain>	Set to <1500>
<Time Constant>	Set to <250ms>
<Filter dB/oct>	Set to <24 dB/oct>
<Trace>	Set <Bottom Window> in <Display> to <X-Noise>

3. Wait until the reading is steady, and then record the maximum value of X-Noise.
4. Set the value of <Ref.Frequency> in the following sequence:

<Ref.Frequency>

9.997 kHz

99.997 kHz

999.997 kHz

9.99997 MHz

59.9997 MHz

5. End the test and fill the result in the performance test form.

7.10 OE2041 Performance Test Record

OE2041 Performance Test Record				
Serial Number _____		Tested By _____		
Firmware Revision _____		Date _____		
Equipment Used _____				
1. Starting Tests				
Pass	_____	Fail	_____	
2. DC Offset				
Input Coupling		Reading		Upper Limit
AC		_____		0.500mV
DC		_____		0.500mV
3. Common Mode Rejection				
Frequency		Reading		Upper Limit
100Hz		_____		1mV
4. Amplitude Accuracy and Flatness				
Sensitivity	Amplitude	Lower Limit	Reading	Upper Limit
1V	1.0000Vrms	0.9800V	_____	1.0200V
200mV	200.00Vrms	198.00mV	_____	202.00mV
100mV	100.00Vrms	98.00mV	_____	102.00mV
20mV	20.000Vrms	19.60mV	_____	20.400mV
10mV	10.000Vrms	9.800mV	_____	10.200mV
Sensitivity	Frequency	Lower Limit	Reading	Upper Limit
200mV	24 kHz	196mV	_____	204mV
200mV	240 kHz	196mV	_____	204mV
200mV	2.4 MHz	196mV	_____	204mV
200mV	24 MHz	196mV	_____	204mV

5. Amplitude Linearity

Sensitivity	Amplitude	Lower Limit	Reading	Upper Limit
1V	1.0000Vrms	0.9900V	_____	1.0100V
	100.00Vrms	0.0990V	_____	0.1010V
	10.000Vrms	0.0099V	_____	0.0101V

OE2041 Performance Test Record

6. Frequency Accuracy

Frequency	Lower Limit	Reading	Upper Limit
10MHz	9.990MHz	_____	10.010MHz

7. SINE OUT Amplitude and Flatness

Sensitivity	SINE OUT Ampl.	Lower Limit	Reading	Upper Limit
1 V	0.800 Vrms	0.388 Vrms	_____	0.412 Vrms
200 mV	0.160 Vrms	77.60 mVrms	_____	82.40 mVrms
50 mV	0.040 Vrms	19.40 mVrms	_____	20.60 mVrms
10 mV	0.008 Vrms	3.880 mVrms	_____	4.120 mVrms

SINE OUT Ampl.	Frequency	Lower Limit	Reading	Upper Limit
1.000 Vrms	24 kHz	0.4850 V	_____	0.5150 V
	240 kHz	0.4850 V	_____	0.5150 V
	2.4 MHz	0.4850 V	_____	0.5150 V
	24 MHz	0.4850 V	_____	0.5150 V

8. DC Outputs and Inputs

Output	Offset	Lower Limit	Reading	Upper Limit
CHOUT1	100.00	9.960V	_____	10.040V
	50.00	4.960V	_____	5.040V
	0.00	-0.030V	_____	0.030V
	-50.00	-5.040V	_____	-4.960V
	-100.00	-10.040V	_____	-9.960V

Output	Offset	Lower Limit	Reading	Upper Limit
CHOUT2	100.00	9.960V	_____	10.040V
	50.00	4.960V	_____	5.040V
	0.00	-0.030V	_____	0.030V
	-50.00	-5.040V	_____	-4.960V
	-100.00	-10.040V	_____	-9.960V

Output	Offset	Lower Limit	Reading	Upper Limit
CHOUT3	100.00	9.960V	_____	10.040V
	50.00	4.960V	_____	5.040V

0.00	-0.030V	_____	0.030V
-50.00	-5.040V	_____	-4.960V
-100.00	-10.040V	_____	-9.960V

OE2041 Performance Test Record

Output	Offset	Lower Limit	Reading	Upper Limit
CHOUT4	100.00	9.960V	_____	10.040V
	50.00	4.960V	_____	5.040V
	0.00	-0.030V	_____	0.030V
	-50.00	-5.040V	_____	-4.960V
	-100.00	-10.040V	_____	-9.960V

Output	Voltage	Lower Limit	Reading	Upper Limit
AUX OUT1	10.000	9.960V	_____	10.040V
	5.000	4.960V	_____	5.040V
	0.000	-0.030V	_____	0.030V
	-5.000	-5.040V	_____	-4.960V
	-10.000	-10.040V	_____	-9.960V

Output	Voltage	Lower Limit	Reading	Upper Limit
AUX OUT2	10.000	9.960V	_____	10.040V
	5.000	4.960V	_____	5.040V
	0.000	-0.030V	_____	0.030V
	-5.000	-5.040V	_____	-4.960V
	-10.000	-10.040V	_____	-9.960V

Output	Voltage	Lower Limit	Reading	Upper Limit
AUX OUT 3	10.000	9.700 V	_____	10.300 V
	5.000	4.900 V	_____	5.100 V
	0.000	-0.030 V	_____	0.030 V
	-5.000	-5.100 V	_____	-4.900 V
	-10.000	-10.400 V	_____	-9.960 V

Output	Voltage	Lower Limit	Reading	Upper Limit
AUX OUT 4	10.000	9.700 V	_____	10.300 V
	5.000	4.900 V	_____	5.100 V
	0.000	-0.030 V	_____	0.030 V
	-5.000	-5.100 V	_____	-4.900 V
	-10.000	-10.400 V	_____	-9.960 V

Input	Voltage	Lower Limit	Reading	Upper Limit
AUX IN 1	10.000	9.960 V	_____	10.040 V
	5.000	4.960 V	_____	5.040 V
	0.000	-0.030 V	_____	0.030 V

	-5.000	-5.040 V	_____	-4.960 V
	-10.000	-10.040 V	_____	-9.960 V
Input	Voltage	Lower Limit	Reading	Upper Limit
AUX IN 2	10.000	9.960 V	_____	10.040 V
	5.000	4.960 V	_____	5.040 V
	0.000	-0.030 V	_____	0.030 V
	-5.000	-5.040 V	_____	-4.960 V
	-10.000	-10.040 V	_____	-9.960 V
Input	Voltage	Lower Limit	Reading	Upper Limit
AUX IN 3	10.000	9.960 V	_____	10.040 V
	5.000	4.960 V	_____	5.040 V
	0.000	-0.030 V	_____	0.030 V
	-5.000	-5.040 V	_____	-4.960 V
	-10.000	-10.040 V	_____	-9.960 V

OE2041 Performance Test Record

Input	Voltage	Lower Limit	Reading	Upper Limit
AUX IN 4	10.000	9.960 V	_____	10.040 V
	5.000	4.960 V	_____	5.040 V
	0.000	-0.030 V	_____	0.030 V
	-5.000	-5.040 V	_____	-4.960 V
	-10.000	-10.040 V	_____	-9.960 V

9. Input Noise

Frequency	Sensitivity	Reading	Upper Limit
997 Hz	50nV	_____	15 nV/VHz
9.997 kHz		_____	10 nV/VHz
99.997 kHz		_____	7 nV/VHz
999.997 kHz		_____	7 nV/VHz
9.99997 MHz		_____	7 nV/VHz
59.99997 MHz		_____	7 nV/VHz

8. OPERATION EXAMPLES

8.1 Simple Signal Measurements

This example will show the OE2041 how to measure the value of R, X, Y, θ . You need two BNC cables to input measure signal and reference signal. We use the function signal generator to generate a 50mVrms, 110MHz sine signal and use the OE2041 to measure it. The steps are below:

Measure a Sine Signal

1. Disconnect all cables from the lock-in. Connect the power source and then turn on the power switch. The system is in default now.

2. Use a BNC cable to connect the output of the function signal generator and the A input of the OE2041. Use another BNC cable to connect the reference signal of the function signal generator and the REF IN of the OE2041, as is shown in Fig.86.

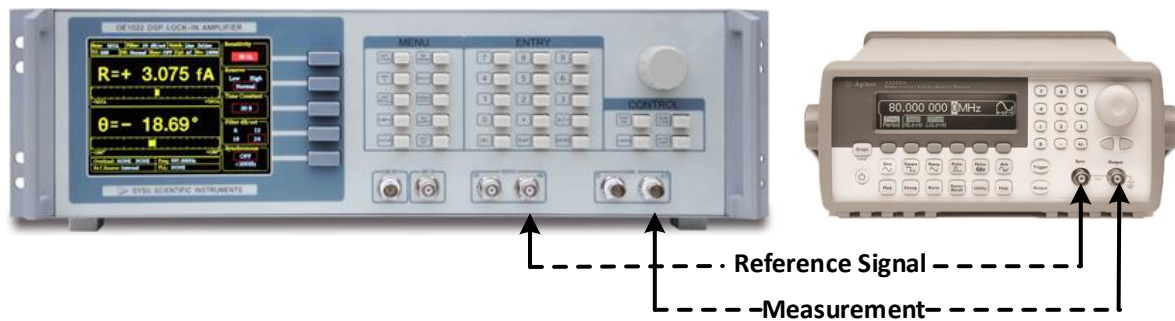

Fig.86 Signal Cable Connection Diagram.

3. Turn on the function signal generator and set “Function: Sine”, “Amplitude: 50mVrms”, “Frequency: 1kHz”, “Output Impedance: 50 Ω ”, as is shown in Fig.87.

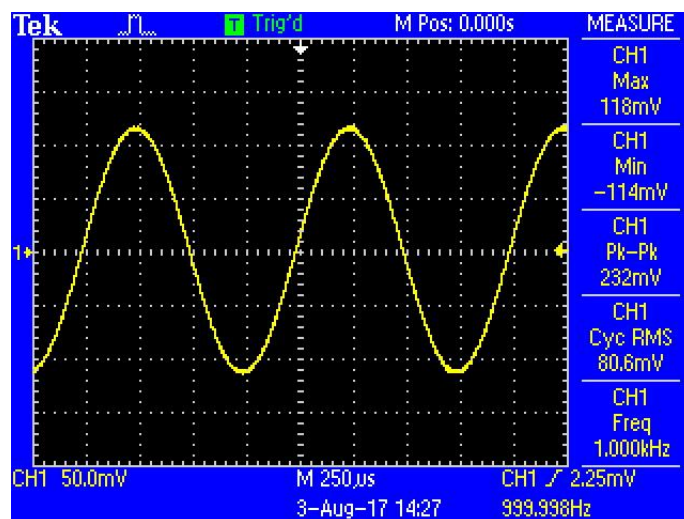

Fig.87 Measured Signal Parameters Diagram

4. Turn on the output of the function signal generator and check whether the scale is overloaded by <Overload>.

Note that if the input of the preamplifier is overload, show <Overload: INPUT NONE>. If the output is overload, show <Overload: NONE GAIN>. If the input and the output are overload at the same time, show <Overload: INPUT GAIN>.

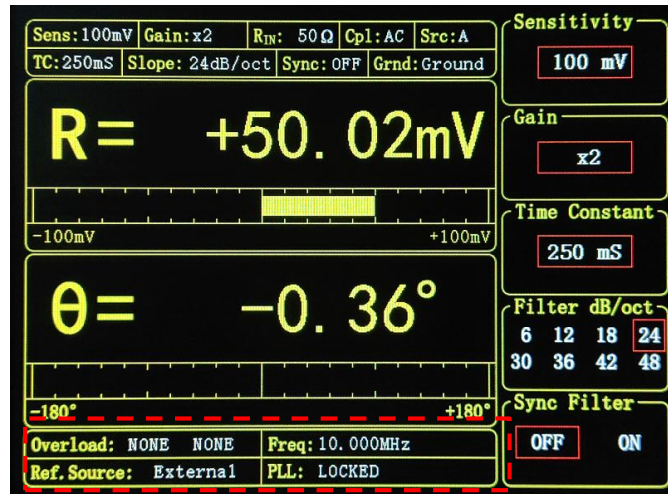

Fig.88 Main Interface Monitoring Bar

When the input of the preamplifier is overload, you should decrease the output amplitude of the function signal generator. If the output gain is overload, you should increase the sensitivity of the OE2041 (the input of the preamplifier will be overload when the peak value is large than 1.5V or the valley value is lower than -1.5V). The default sensitivity is <100mV>. So, this case will not be overload. If you need to adjust the sensitivity, the steps are as below.

5. Press [GAIN/TC] as below and then change <Sensitivity>.



Fig.89 [GAIN/TC] Menu

Press the [Soft Key 2] to choose <Sensitivity> and then <Sensitivity> will be lighted. Spin the knob to change <Sensitivity> so that there is no overload and the full scale is the maximum. In this case, the sine wave from the function signal generator is measured like Fig.90. The result of measurement is: $R=50.02\text{ mV}$, $\theta=-0.36^\circ$.

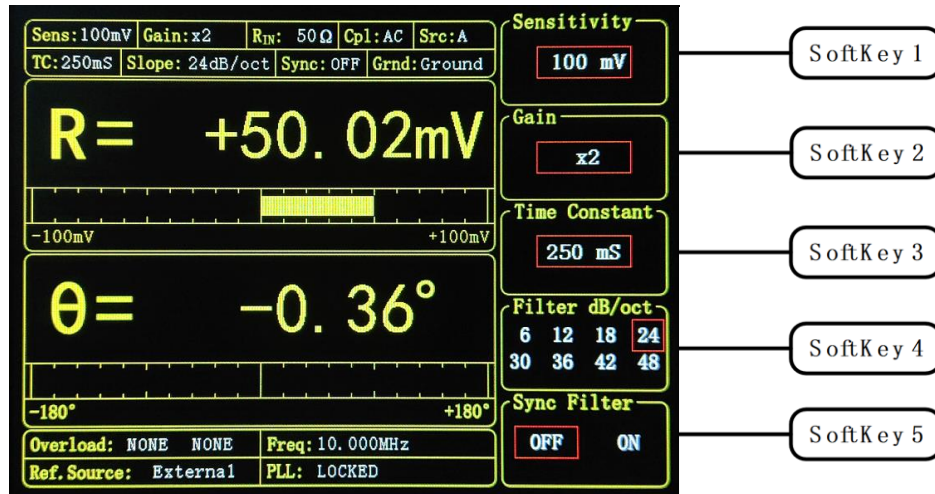

Fig.90 GAIN/TC Menu Interface

6. The main interface data bar displays the value of <R>, <X>, <Y> and <θ>. Press the [DISPLAY] to enter the submenu, as is shown in Fig 91.

It is a default that the top area of the data filed displays <R> and the bottom area of the data filed displays <θ>, as is shown in Fig.92.

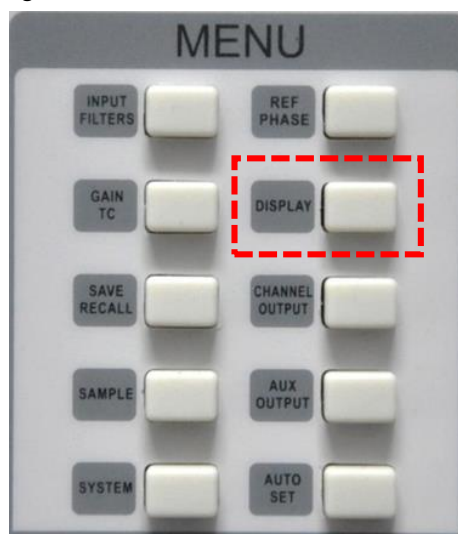

Fig.91 [DISPLAY] MENU

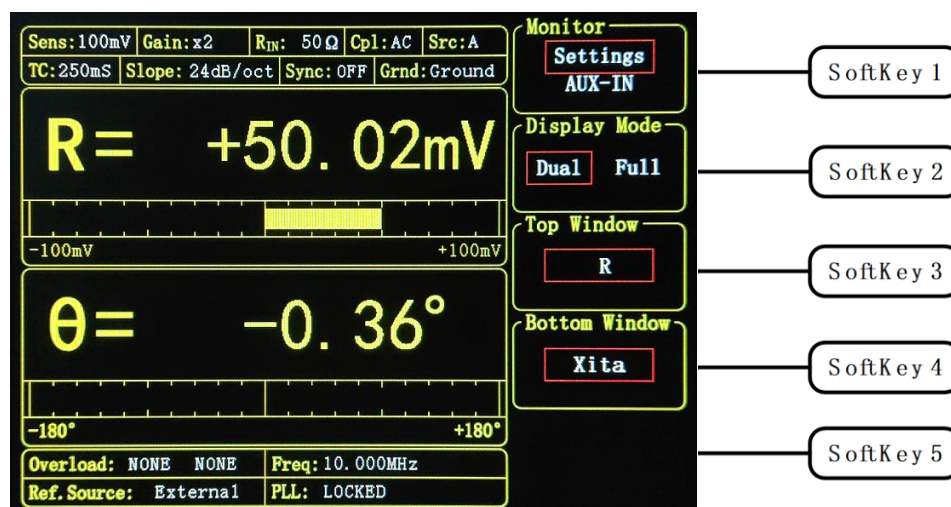

Fig.92 [DISPLAY] Menu Interface

You can change the display way according to steps below.

First, press the [Soft Key 3] in [Display] submenu to choose <Top Window> and spin the knob to choose <X>. Second, press [Soft Key 4] to choose <Bottom Window> and spin the knob to choose <Y>. After these settings, the result is shown in Fig.93.

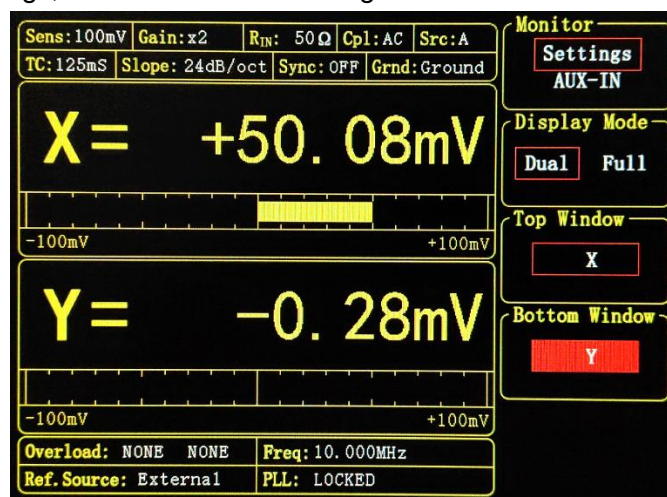

Fig.93 X|Y Display

8.2 Harmonics Measurements

This example will show how to measure harmonic component of the input signal. You need two BNC cables to measure the input measure signal and reference signal. Use the function signal generator to provide a 160mVpp, 1kHz square wave and then measure the 1st, 3rd, 5th, and 7th order harmonic. The steps are below.

1. Disconnect all cables from the lock-in. Connect the power source and then turn on the power switch. The system is default.
2. Use a BNC cable to connect the output of the function signal generator and the A/I input of the OE2041. Use another BNC cable to connect the reference signal of the function signal generator and the REF IN of OE2041, as is shown in Fig.94.

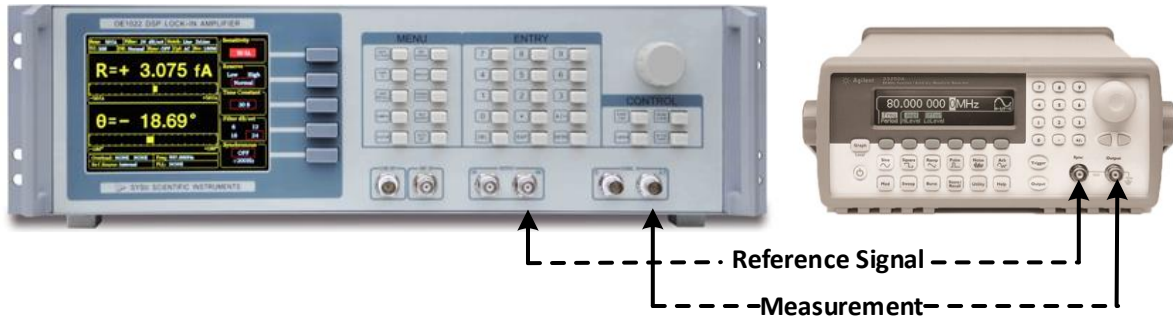

Fig.94 Signal Cable Connect Diagram

3. Turn on the function signal generator and set “Function: Square”, “Amplitude: 80mVrms”, “Frequency: 1 kHz”, as is shown in Fig.95.

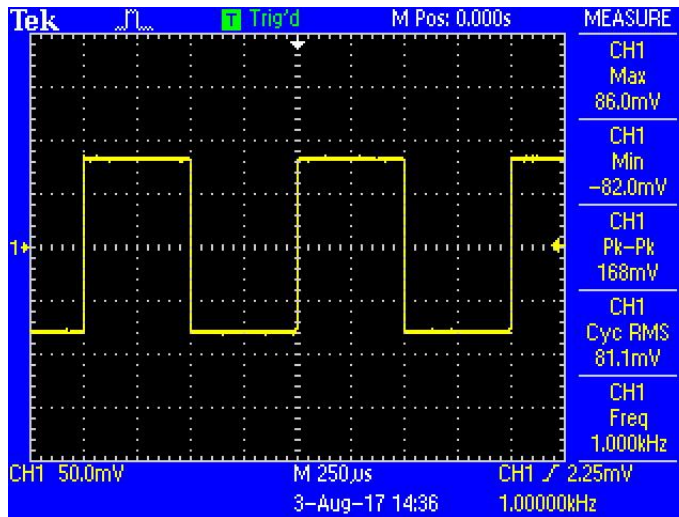

Fig.95 Measured Signal Parameter Diagram

4. Press [DEMODO] button to enter the submenu, as is shown in Fig.96.

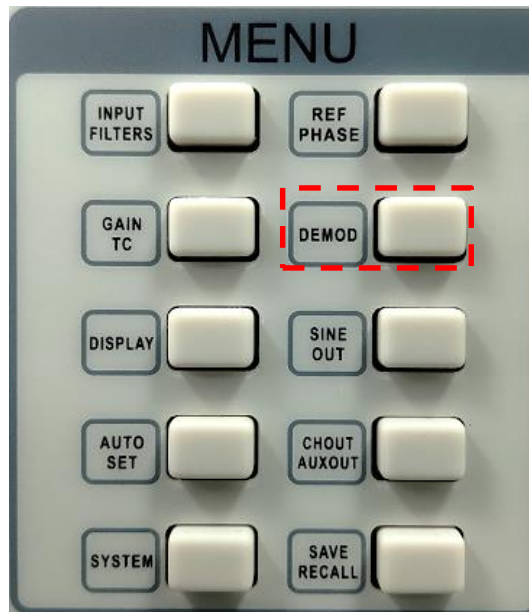

Fig.96 [DEMODO] MENU

Interface of [DEMODO] submenu is as shown in Fig.97

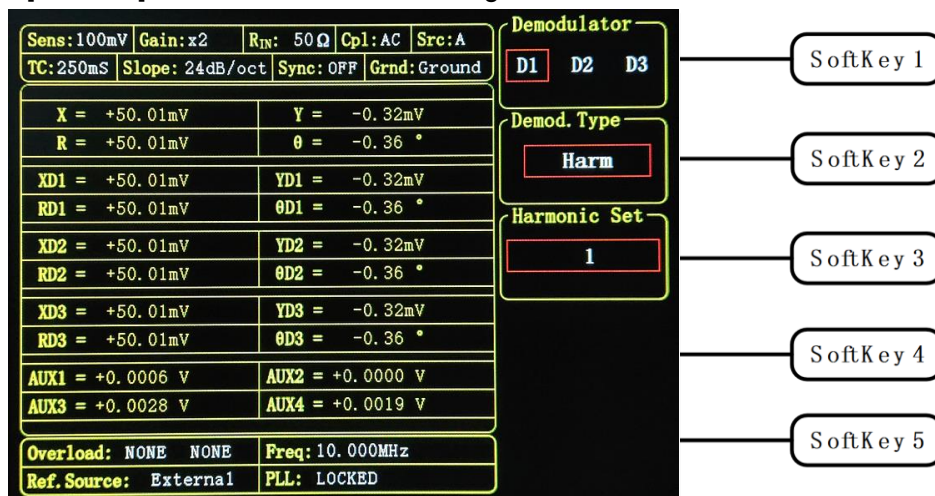

Fig.97 [DEMODO] Submenu

Set the harmonic order in <Harmonic Set> secondary submenu and use keyboard to choose order. The operation method of measuring the 1st, 3rd, 5th, and 7th order harmonic of the input square wave at the same time is below, as is shown in Fig.98.

First, press the [Soft Key 1] to choose 3 demodulator channels and press the [Soft Key 2] to set the Demod.Type of all demodulators as <Harm>. Second, press the [Soft Key 3] when Demodulator <D1> is chosen and set the harmonic order as 3. Third, press the [Soft Key 3] when Demodulator <D2> is chosen and set the harmonic order as 5, and then, press the [Soft Key 3] when Demodulator <D3> is chosen and set the harmonic order as 7. At last, press the [Soft Key 2] in [DISPLAY] submenu to set <Display Mode> as <Full>.

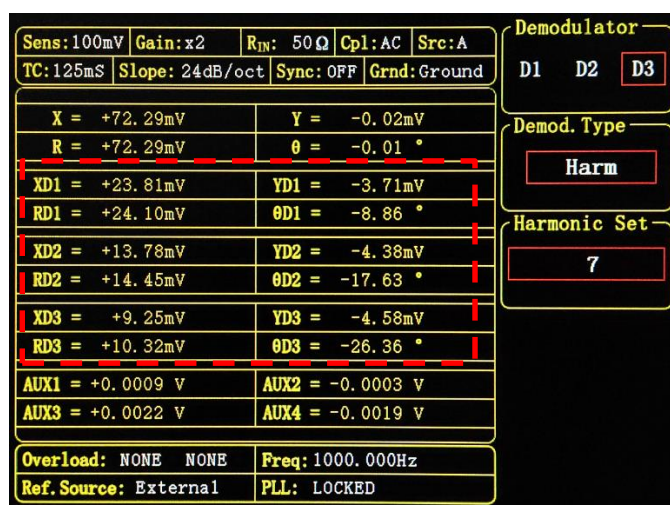

Fig.98 The 3rd Harmonic Measurement Result

How to get the amplitude of nth harmonics

Calculate the harmonic theoretical value of the square wave: suppose that the peak-peak value

of square value is E and the angular frequency is ω . After Fourier expand, the result is:

$$f(t) = \frac{2E}{\pi} \left(\sin(\omega t) + \frac{1}{3} \sin(3\omega t) + \frac{1}{5} \sin(5\omega t) \cdots + \frac{1}{n} \sin(n\omega t) \right)$$

Where the n times harmonic is sine wave:

$$f(t) = \frac{2E}{n\pi} \sin(n\omega t)$$

Therefore, the valid value of n times harmonic is:

$$R = \frac{\sqrt{2}E}{n\pi}$$

We can verify that whether the measure result is close to the theoretical result or not. In this example, the E is 160mV, and the result of 1st order harmonic is:

$$R = \frac{\sqrt{2} \times 160}{1 \times \pi} mV \approx 72.025 mV$$

The result of 3rd order harmonic is:

$$R = \frac{\sqrt{2} \times 160}{3 \times \pi} mV \approx 24.008 mV$$

The result of 5th order harmonic is:

$$R = \frac{\sqrt{2} \times 160}{5 \times \pi} mV \approx 14.405 mV$$

The result of 7th order harmonic is:

$$R = \frac{\sqrt{2} \times 160}{7 \times \pi} mV \approx 10.289 mV$$

Compare the measure result with theoretical result according the above method.

8.3 Optical Spectral Measurement

This case shows how to measure a spectral diagram of any light source. You need a light chopper (such as SIGNAL RECOVERY MODEL 197 Light Chopper), a grating monochromator (such as WDG15-Z) and its control system, a photoelectric detector (for example. the electric probe uses the Si photo diode of the S2368 series by Hamamatsu, which is a Japan Inc.), a data collection platform (such as NI cDAQ-9172) and a PC computer. You should control the monochromator to auto sweep in the spectral measurement range. And then measure the photo current using the

OE2041. The steps are below:

1. Disconnect all cables from the lock-in. Connect the power source and then turn on the power switch. The system is default.

2. Set the corresponding parameters of OE2041.

(1) Press [INPUT/FILTERS] and then set the input mode to <I> and <Amplitude: 1M>. Others do not change.

(2) Press [REF/PHASE] and then set <Ref. Source: External> and <Type: TTL>.

(3) Press [GAIN/TC] and then set <Sensitivity: 1 μ A> which can be adjusted practically, <Reserve: Normal>, <TC: 300ms> and <Roll off: 12dB/oct>. Finally, turn off the SYNC filter.

(4) Press [OUTPUT/OFFSET] and then set <CH1>, <Source: R> and <Speed: Fast>.

3. Build the spectral measurement platform.

Use a BNC cable to connect the output of the photoelectric detector and the A/I input of the OE2041.

Use a BNC cable to connect the Sync out f1 of the light chopper and the REF IN of the OE2041.

Use a BNC cable to connect the data collection platform and the CH1 OUT of the OE2041.

The sketch is shown in Fig.99

The actual connect figure is shown in Fig.100

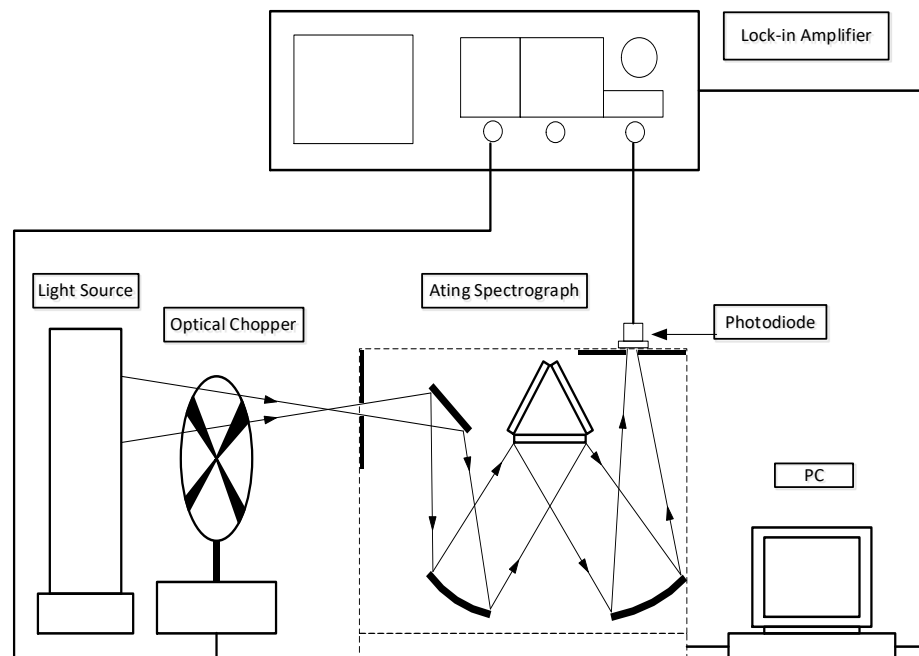

Fig.99 Optical Measurement Platform Diagram



Fig.100 Optical Measurement Platform Picture

4. Start the spectral measurement and collect data from the data collection platform. Then, you will get an uncalibrated spectral image as is shown in Fig.101

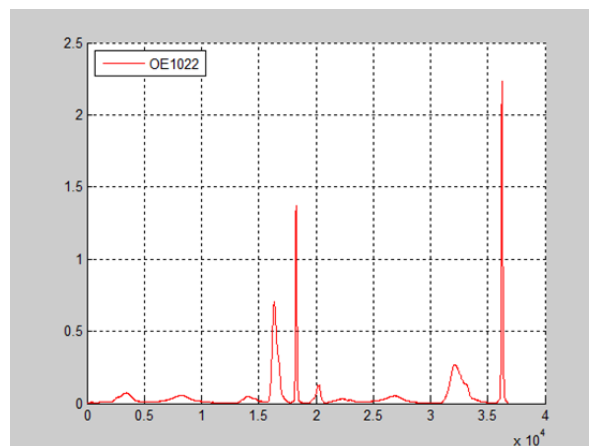

Fig.101 OE2041 Detected Spectrum Curve Chart

5. Change the OE2041 to the SR830. Repeat the steps above to run the same experiment. Then you will get another spectral image as is shown in Fig.102. You can see that these two images are almost the same.

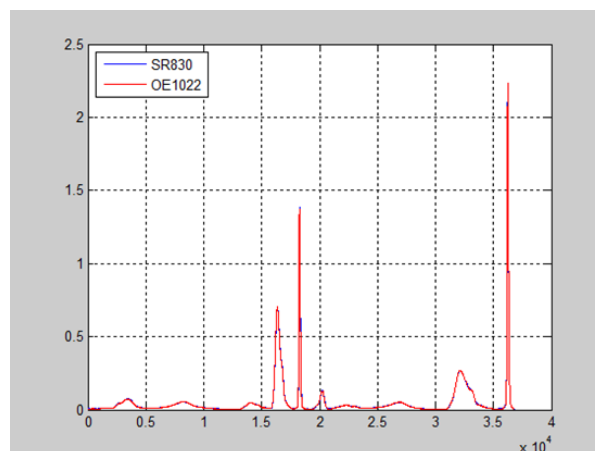

Fig.102 The Contrast Spectrum Chart between SR830 and OE2041

8.4 Serial Communication

This example will demonstrate the OE2041 remote control serial/USB2.0 environment setup and debugging operation. You need a USB2.0 TypeB cable. Do the steps in the following sequence:

1. Use a USB cable to connect the USB of the OE2041 to the USB of one PC.
2. The PC will recognize the USB device and remind to install the driver program. If your PC system is WIN7/8/8.1, the PC will not do these automatically. You need to install the driver manually according to the Chapter 6.1.
3. Open the "Uart_Assistant" folder in CD and double click the file UartAssist.exe. Then you see the software interface, as is shown in Fig.103.

This software contains communication settings, receive area settings, send area settings, receive area, and send area.

The default baud rate of OE2041 serial port is 921600, with no parity bit, 8 data bits, and 1 stop bit (the baud rate and parity bits of OE2041 can be set through the RS232 menu option on the front board menu, etc.).

Since the USB2.0 driver is a virtual serial port, it is the same as the RS232 serial port, so you need to select the COM port automatically assigned by the computer for the OE2041. The COM port number can be viewed through the ports (COM and LPT) option in the device manager, as is shown in Fig.104.

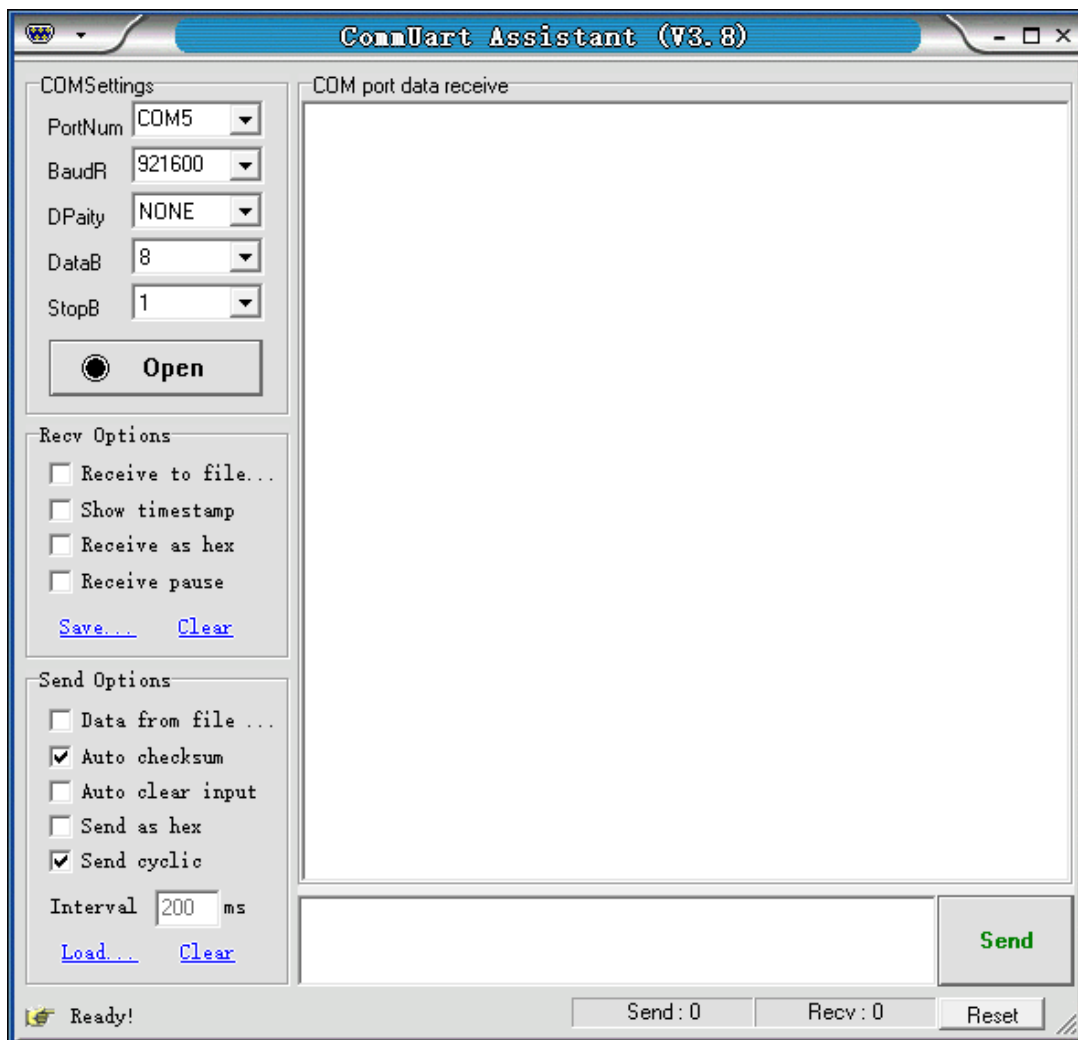



Fig.103 “CommUart Assistant” Software display

2) After these settings are completed, if you see a black circle like , you need to click the button to make it red like . If you cannot make it red, please check the COM number and repeat the click. If the connection is OK, you will see Fig.105.

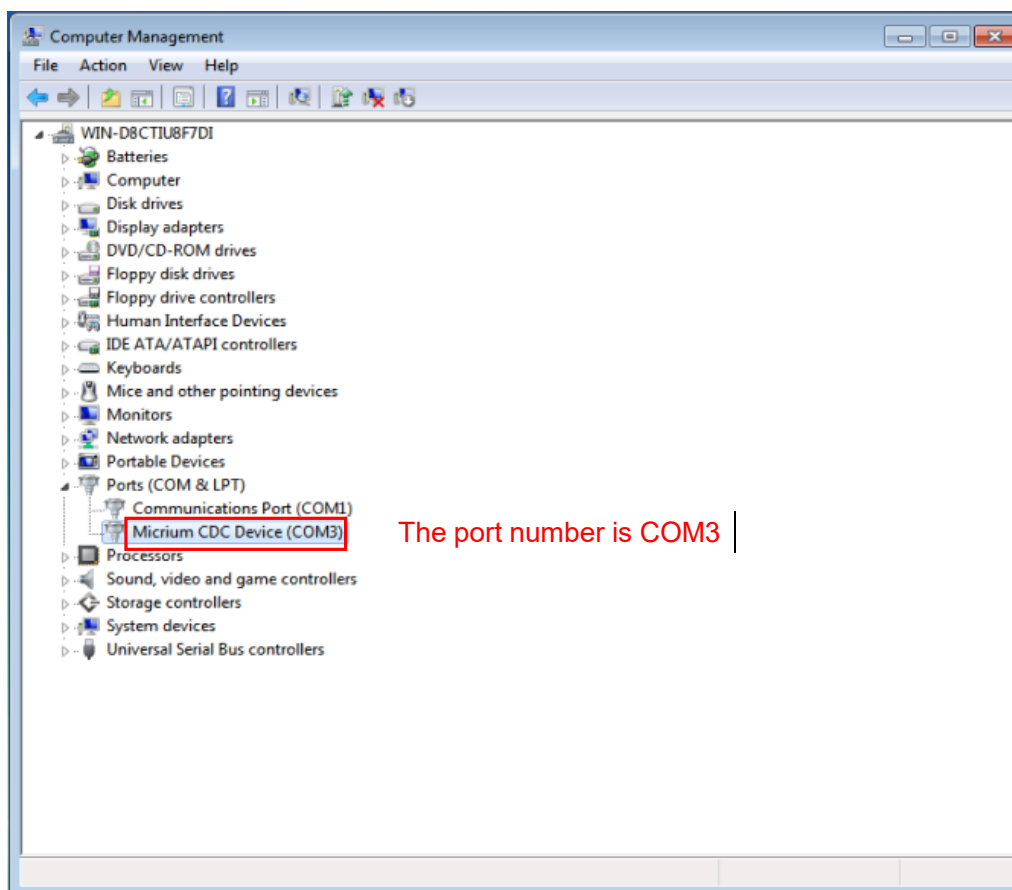

Fig.104 Check the USB COM number at “Device Manager”

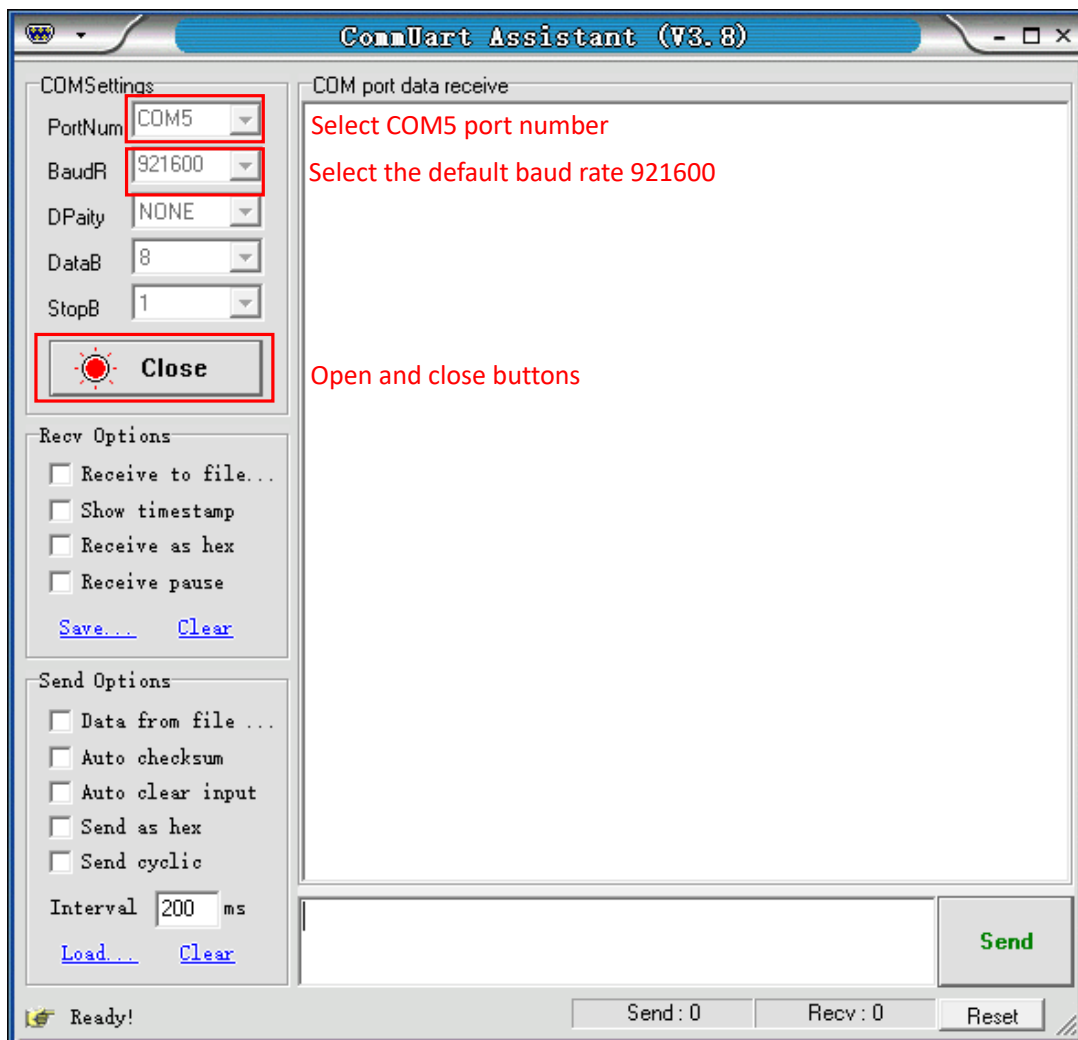

Fig.105 USB connection succeeds

4. Transfer commands to communicate with the OE2041.

1) The commands consist of four capital letter mnemonics and several parameters. Several commands at the same line are separated by semicolons. More details see the Chapter Remote Programming. Note that you must append a carriage return or the hexadecimal number 0D to the end of the command in order to execute the current command effectively. To send a command, first type the command in the send area, then hit the carriage return immediately afterwards, and finally click the send button, after that the command will be sent. The result is like the Fig.106 and Fig.107.

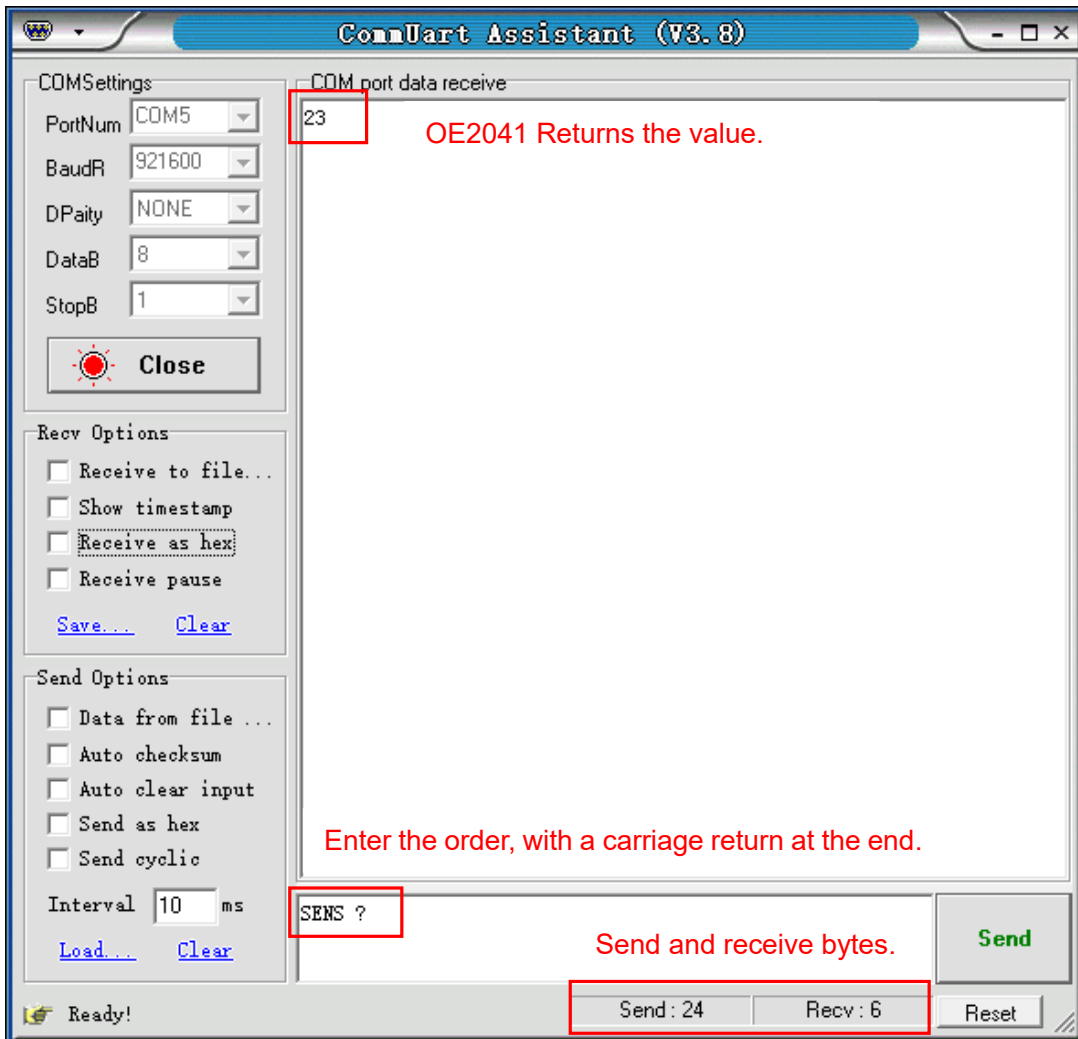

Fig.106 ASCII words send and receive instructions

At the same time, the serial debugging assistant can be configured to automatically add the carriage return character 0X0D. Click the "Auto checksum" option in the send options, select the Fixed Byte Checksum in the pop-up window, and set the value to the hexadecimal value "0D", as is shown in Fig.108.

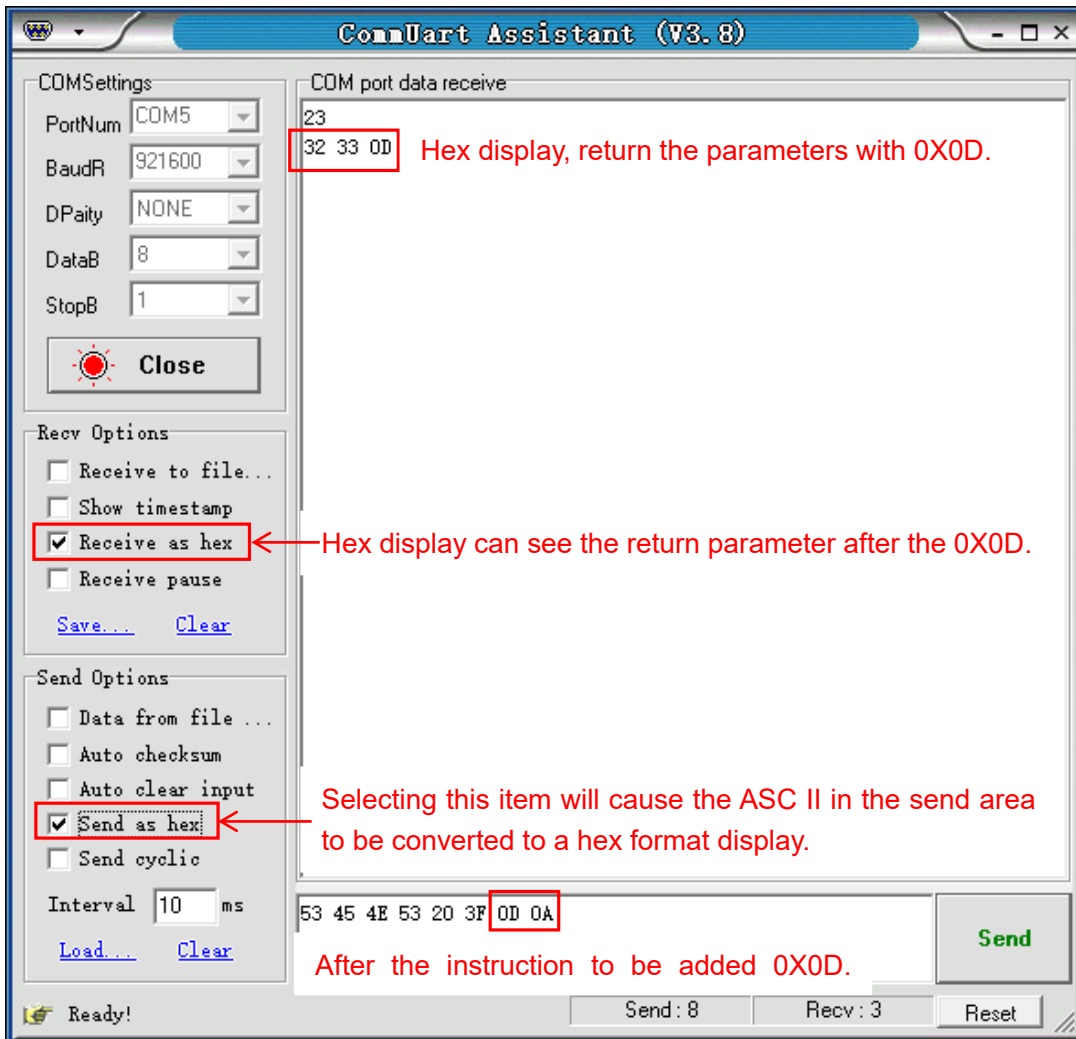

Fig.107 Send and receive HEX instructions

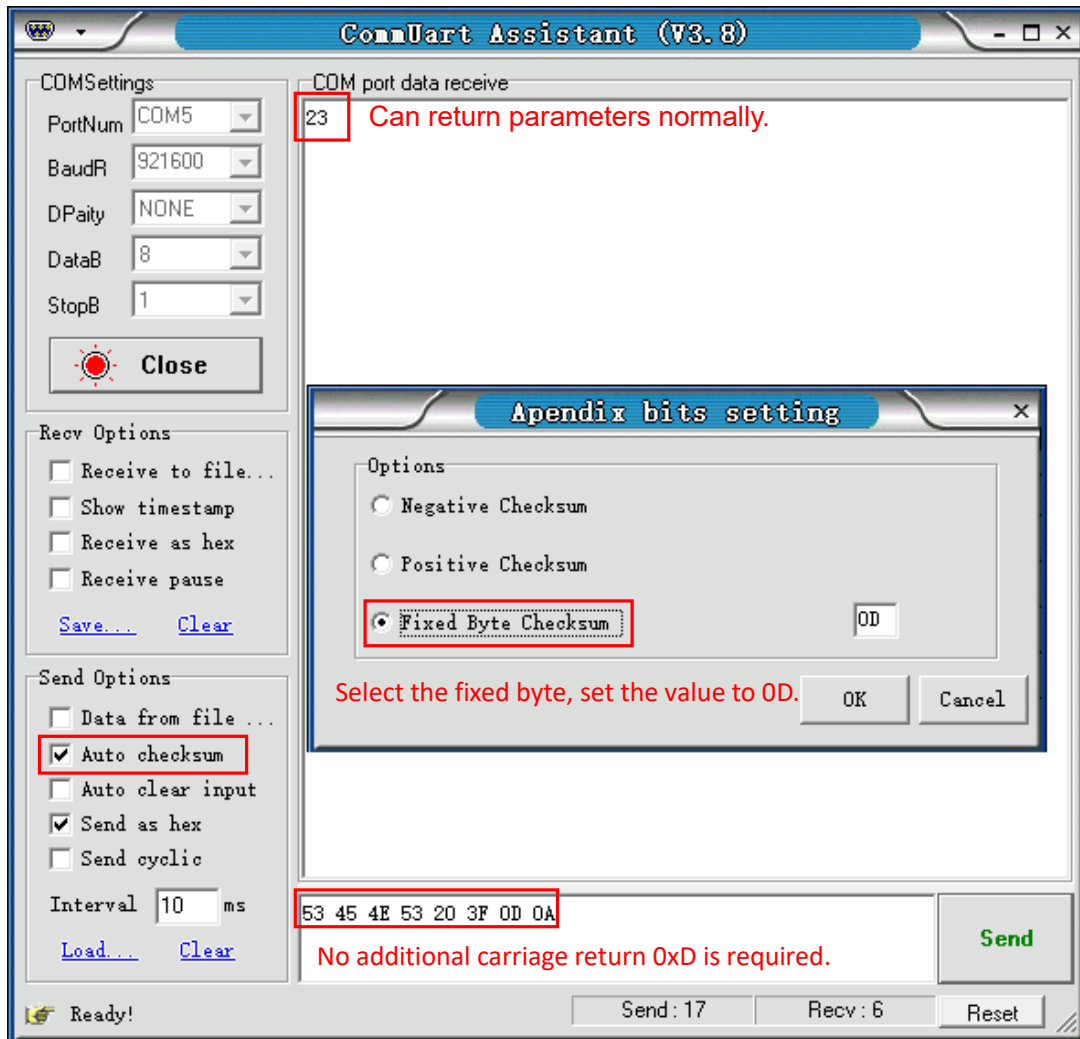

Fig.108 Checksum Settings

Multiple commands need “;” to separate each other, such as “SENS 24;FMOD 1;FREQ 1000;SENS ?;FMOD ?;FREQ ?” like Fig.109.

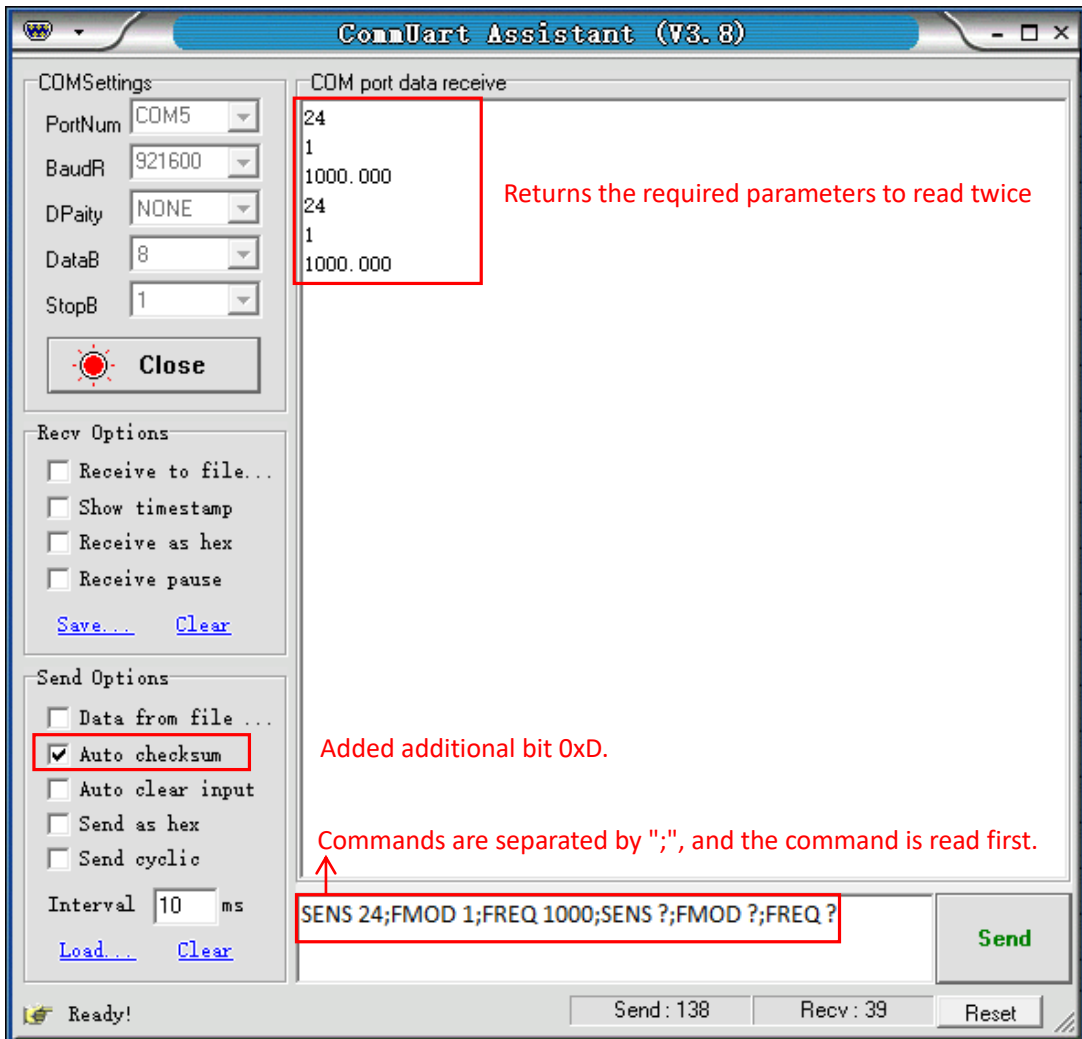

Fig.112 The execution of multiple commands

If you want to read <X>, <Y>, <R>, <θ> and Freq continuously, you can set the send interval as Fig.110 and Fig.111.

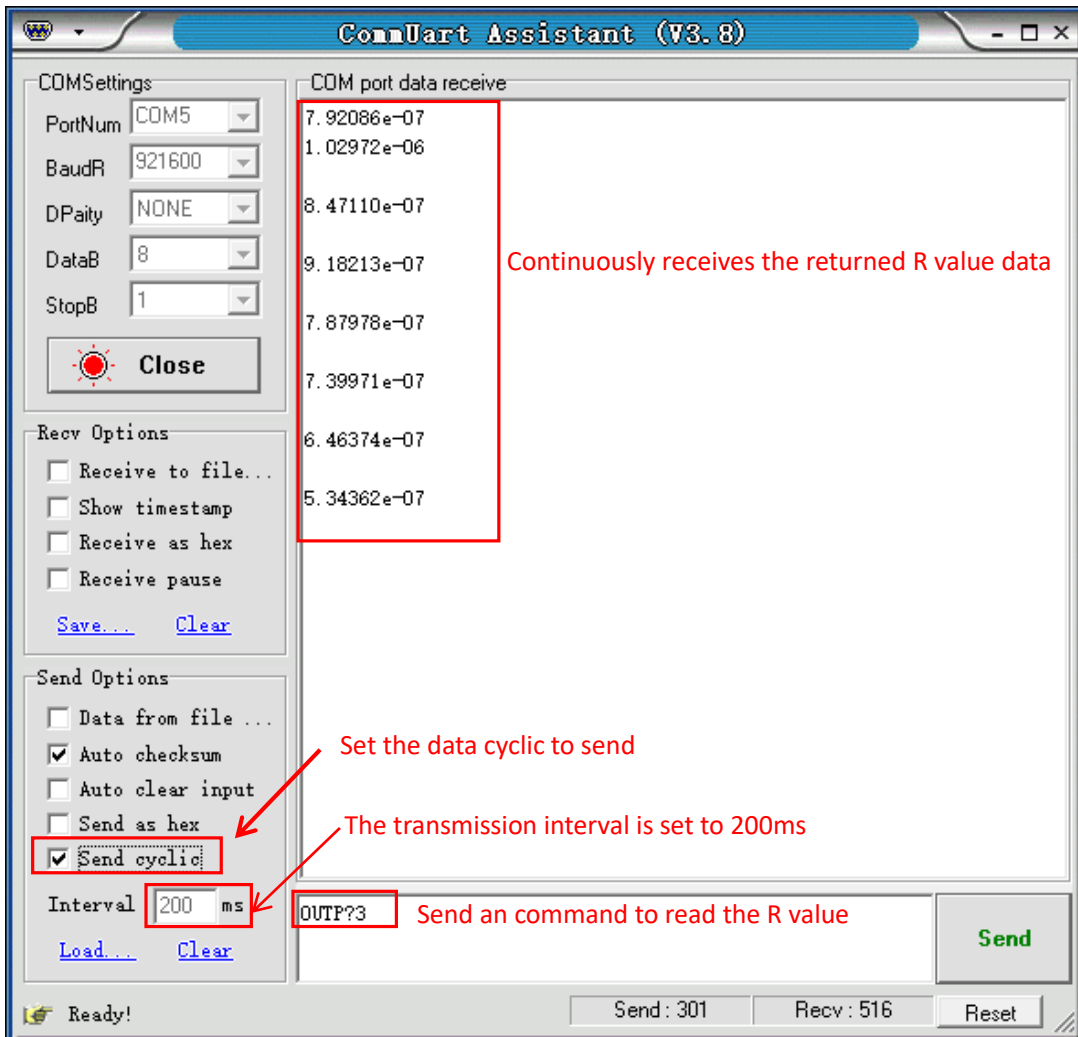

Fig.110 Continuous read single R value

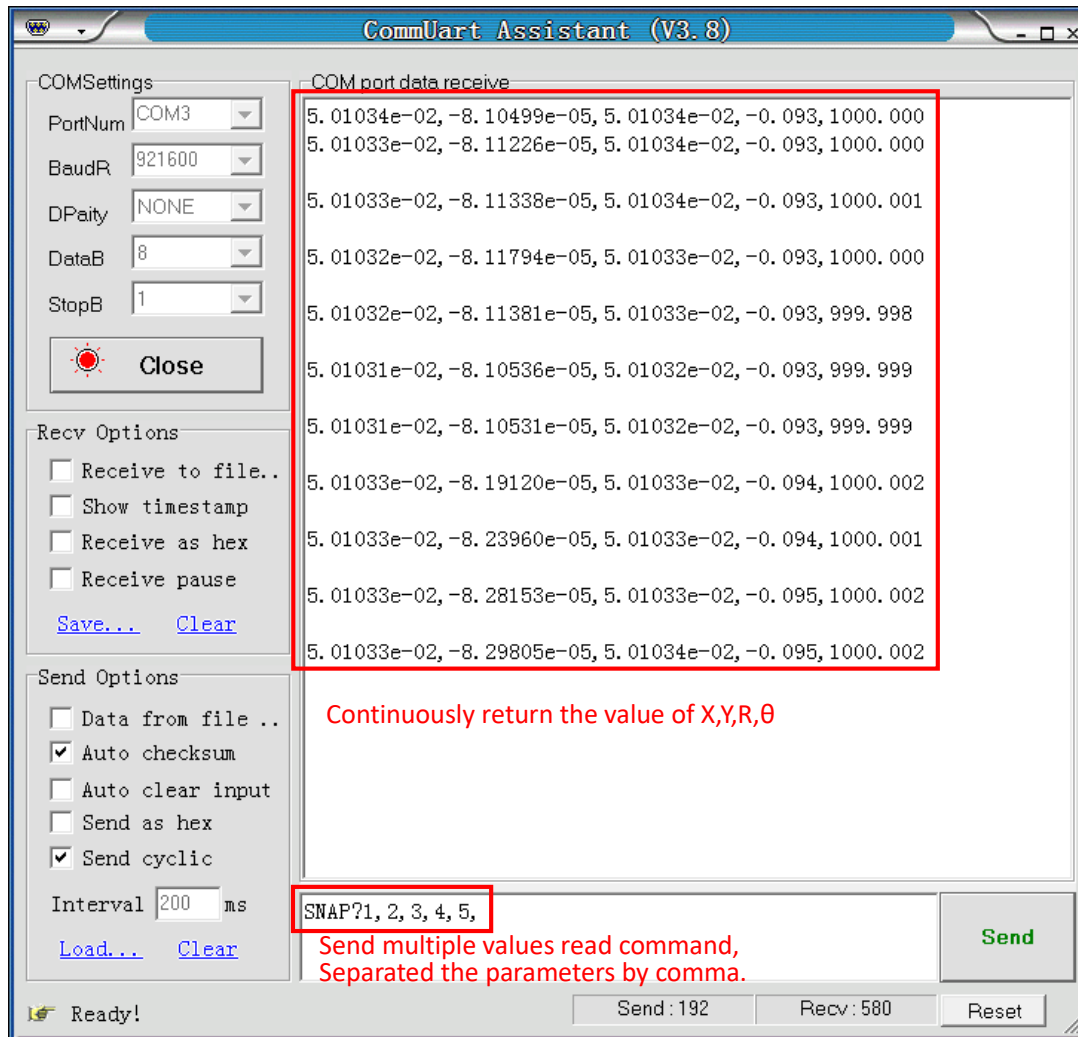

Fig.111 Continuous read the Value of X, Y, R θ and Freq

Note that when use this program to control the OE2041, the LCD display will refresh at the same time. For example, if <Sens: 100mV> equals to the “25” commands, <Sens> will become <Sens: 50mV> when the OE2041 receives the “24” command.

The OE2041 can use many versions of this kind of serial debugging program. You can use other programs to control the OE2041 remotely.